

Interfacing Analog Transmitters to FOUNDATION™ Fieldbus

INSTALLING THE MODEL 848T WITH AN ANALOG CONNECTOR

The analog connector converts the 4–20 mA signal to a 20–100 mV signal. The Model 848T transmitter uses a standard mV sensor type to output the scaled 4–20 mA signal onto the FOUNDATION fieldbus.

Use the following steps when installing the Model 848T with the analog connector:

1. The Model 848T, when ordered with option code S002, comes with four analog connectors. Replace the standard connector with the analog connector on the desired channels.
2. Wire one or two analog transmitters to the analog connector according to Figure 1-1. There is space available on the analog connector label for identification of the analog inputs.

NOTE

Power supply should be rated to support the connected transmitter(s).

3. If the analog transmitters can communicate using the HART protocol, the analog connectors are supplied with the ability to switch in a 250 ohm resistor for HART communication (see Figure 1-2).

One switch is supplied for each input (top switch for “A” inputs and bottom switch for “B” inputs). Setting the switch in the “ON” position (to the right) bypasses the 250 ohm resistor. Terminals are provided for each analog input to connect a HART communicator for local configuration.

Model 848T

Figure 1-1. Model 848T Analog Input Wiring Diagram

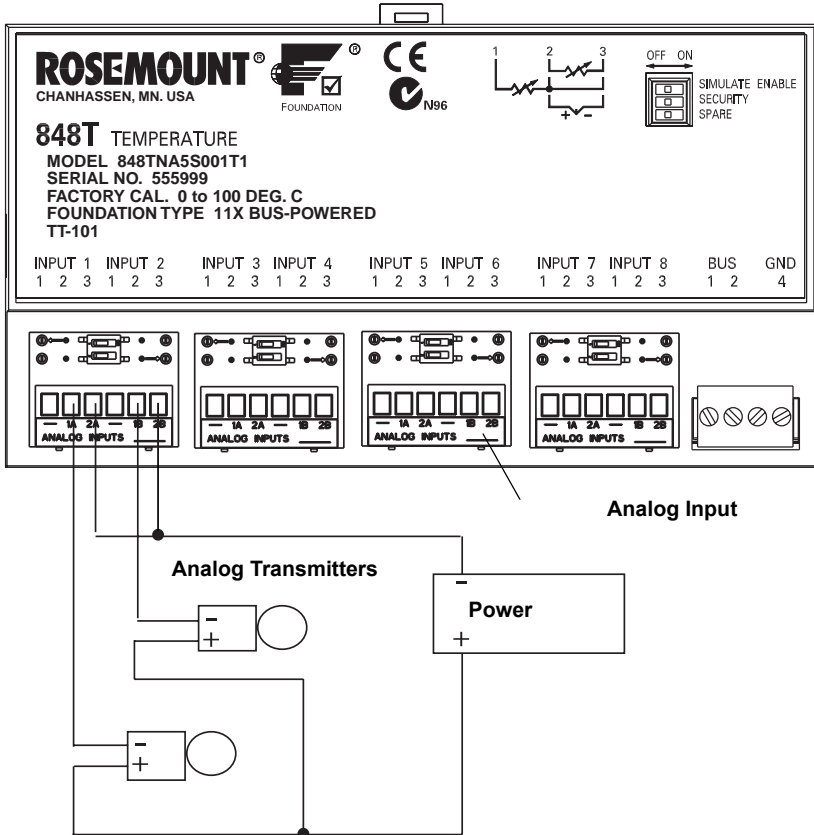
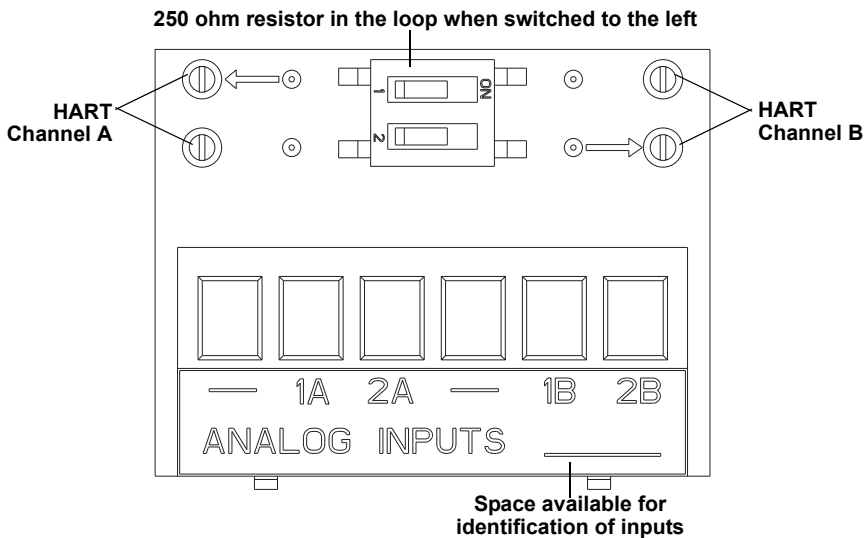

Figure 1-2. Model 848T Analog Connector



Model 848T

CONFIGURING THE MODEL 848T WITH THE ANALOG CONNECTOR

Sensor Transducer Block Configuration

Use the sensor configuration method to set the sensor type to mV – 2-wire for the applicable transducer block or follow these steps.

1. Set the MODE_BLK.TARGET to out of service (OOS).
2. Set the SENSOR_TYPE to mV.
3. Set the MODE_BLK.TARGET to AUTO.

Analog Input Block Configuration

Follow these steps to configure the applicable Analog Input Block:

1. Set the MODE_BLK.TARGET to OOS.
2. Set CHANNEL to the transducer block configured for the analog input.
3. Set XD_SCALE.EU_0 to 20
Set XD_SCALE.EU_100 to 100
Set XD_SCALE.ENGUNITS to mV
4. SET OUT_SCALE to match the desired scale and units for the connected analog transmitter.
Flow Example: 0 – 200 gpm
OUT_SCALE.EU_0 = 0
OUT_SCALE.EU_100 = 200
OUT_SCALE.ENGUNITS = gpm
5. Set L_TYPE to INDIRECT.
6. Set the MODE_BLK.TARGET to AUTO.