

# Model 3001C Hydrostatic Pressure Transmitter

## FEATURES

- *High accuracy overall temperatures and pressures*
- *Proven sensor technology*
- *Microprocessor-based electronics*
- *Digital communications via HART® protocol*
- *Dual-compartment housing*
- *Explosion-proof and intrinsically safe design*
- *Continuous diagnostics*



## Content

Specifications . . . . .	page Level-29
Hazardous Locations Certifications . . . . .	page Level-31
Dimensional Drawings . . . . .	page Level-32
Ordering Information . . . . .	page Level-35
HTG Product Data Sheets . . . . .	page Level-36

# Model 3001C

## Model 3001C Overview

### INTRODUCTION

The Model 3001C Hydrostatic Pressure Transmitter\* is the heart of the Rosemount Hydrostatic Tank Gauging System (HTG). This highly accurate sensor provides the primary pressure measurement on which the HTG calculations are based. These calculations provide on-line measurements of mass, density, standard density, volume, standard volume, and level in liquid storage tanks.

Depending on the application, one or two Model 3001C Pressure Transmitters are used per storage tank. One transmitter is used if the density is constant and the second transmitter is used if the density needs to be measured. A Model 1151S, 3051C, or 3001 Pressure Transmitter must be mounted on top of the tank to correct for ullage pressure.

### PROVEN SENSOR TECHNOLOGY

The Model 3001C is based on the proven capacitance cell technology used in the Model 1151 and 3051 Pressure Transmitters. This sensor provides reliable measurements needed for inventory control and product transfers.

The Model 3001C incorporates a high accuracy and a free floating sensor based upon the high standards of the Rosemount Model 3051 product line. The Model 3001C transmitters are specially characterized over all operating temperatures (–40 to 185 °F [–40 to 85 °C) and pressures (range dependent) to provide the high performance required for tank gauging applications.

### OPERATION

When process pressure is applied, the isolating diaphragm is displaced, transmitting the measured pressure through the filled system to the sensing diaphragm. This pressure displaces the sensing diaphragm in the sensor cell, creating a differential capacitance between the diaphragm and the capacitor plates. The differential capacitance between the sensing diaphragm and the capacitor plates, as well as a temperature sensor measurement, are converted to digital data for correction and linearization in the microprocessor.

FIGURE 1. The Hydrostatic Tank Gauging System Components



HTG 008AB

### MICROPROCESSOR-BASED TRANSMITTER

Because the Model 3001C transmitter is microprocessor-based, it provides complete signal characterization internally corrected for temperature. The design permits testing and configuration of the transmitter by a HART-based communicator. The microprocessor arrangement allows transmitters to be interchanged without reconfiguring any other components within the HTG system. This stand-alone modular concept is employed on all of the HTG System components to provide maximum flexibility for any tank gauging system design. The pressure transmitter provides secure digital communications using the HART protocol in which the Model 3201 HIU or Model 3202 SAM is the master device and the Model 3001C is the slave device.

### EASE OF INSTALLATION

Dual-compartment electronics allow field terminal connections to be made without entry into the transmitter electronics, simplifying installation. Model 3001C transmitters are factory characterized to ensure extreme accuracy. Commissioning is easily accomplished, because there are no span requirements. Once addressed, the transmitter is quickly zeroed in place with a HART-based communicator or the Model 3601 PCConfig System Software. The rugged enclosure of the Model 3001C Pressure Transmitter makes it suitable for operation in hazardous areas.

## Specifications

### FUNCTIONAL SPECIFICATIONS

#### Pressure Range

##### Code

- 2 0 to 9 psi (0 to 62 kPa)
- 3 0 to 30 psi (0 to 207 kPa)
- 4 0 to 150 psi (0 to 1,040 kPa)

#### Temperature Range Limits

##### Process<sup>(1)</sup>

**Silicone Fill Sensor**  
–40 to 230 °F (–40 to 110 °C)

**Inert Fill Sensor**  
0 to 185 °F (–18 to 85 °C)

##### Ambient

–40 to 185 °F (–40 to 85 °C)

##### Storage

–50 to 230 °F (–46 to 110 °C)

##### Humidity Limits

0 to 100% relative humidity

##### Overpressure Limits

The transmitter sensor can range from 0 psia to 3,626 psig on either side without damage to the transmitter.

The actual pressure limit is dependent on the type of process connection as listed below.

**Stainless Steel Class 150**  
**Process Connection Code A or Code M)**  
0.5 psia to 275 psig at 100 °F (38 °C)

**Stainless Steel Class 300**  
0.5 psia to 720 psig at 100 °F (38 °C)

**Carbon Steel Class 150 (Option Code G1)**  
0.5 psia to 285 psig at 100 °F (38 °C)

**Carbon Steel Class 300 (Option Code G2)**  
0.5 psia to 740 psig at 100 °F (38 °C)

**Coplanar (Option Code R1, R2, R3, or R4)**  
0.5 psia to 10,000 psig burst pressure

##### Remote Seal (Option Code S1)

Refer to Model 1199 Remote Seal Product Data Sheet PDS 4016

##### Signal Output

2-wire digital communications using HART Protocol

##### Power Supply

Power is supplied by the Model 3201 HIU or Model 3202 SAM. Transmitter operates on 10.5 to 55 V dc with no load.

##### Static Pressure Limit

Operates within specifications between static line pressures of 0.5 psia to 3,626 psig.

##### Load Limitations

Maximum loop resistance is determined by the voltage level of the external power supply as described by:

**Max. Loop Resistance = 43.5 (Power Supply Voltage-10.5)**

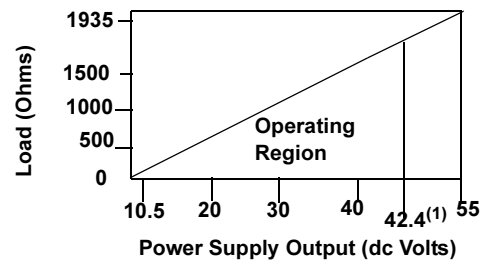

Communication requires a minimum

loop resistance of 250 ohms.

(1) For CSA approval, power supply must not exceed 42.4 V.

##### Turn-on Time

Performance within specifications less than 2.0 seconds after power is applied to transmitter.

##### Damping

Output response to a step input change will be from 0–36 seconds for one time constant. This is in addition to sensor response time of 0.2 seconds.

### PERFORMANCE SPECIFICATIONS

#### Digital Accuracy

##### Reference Accuracy

±0.02% URL

##### Total Performance

±0.05% URL includes worst case error from –40 to 185 °F (–40 to 85 °C)

(1) Process temperatures above 185 °F require derating the ambient limits by a 1.5:1 ratio.

## Mounting Position Effect

Zero shift of up to 1.25 in H<sub>2</sub>O (0.31 kPa) that can be calibrated out—No span effect

### Static Pressure Effect

Only applicable for differential pressure applications with static pressure applied to the transmitter.

### Zero Error (can be calibrated out at line pressure)

±0.01% of URL /100 psi (.69 MPa)

### Span Error

±0.02% of reading/100 psi (.69 MPa)

## PHYSICAL SPECIFICATIONS

### Electrical Connections

<sup>1</sup>/<sub>2</sub>-14 NPT, PG 13.5, and CM 20 conduit. HART-based communicator connections permanently fixed to the terminal block.

### Process Connections

#### 2-inch Stainless Steel ANSI Class 150 Flange

(Process Connection Code A)

#### 2-inch Stainless Steel ANSI Class 300 Flange

(Process Connection Code B)

#### 3-inch Stainless Steel ANSI Class 150 Flange

(Process Connection Code M)

#### 3-inch Stainless Steel ANSI Class 300 Flange

(Process Connection Code N)

#### 3-inch Carbon Steel ANSI Class 150 Flange

(Process Connection Code X and Option Code G1)

#### 3-inch Carbon Steel ANSI Class 300 Flange

(Process Connection Code X and Option Code G2)

#### DIN DN50 PN40 Stainless Steel Flange

(Process Connection Code E)

#### DIN DN80 PN 40 Stainless Steel Flange

(Process Connection Code F)

#### Stainless Steel Coplanar Flange with <sup>1</sup>/<sub>4</sub>-18 NPT on 2<sup>1</sup>/<sub>8</sub>-inch Centers, One Drain/Vent Valve.

(Process Connection Code X and Option Code R1)

#### Stainless Steel Coplanar Flange with <sup>1</sup>/<sub>2</sub>-14 NPT Adapters on 2<sup>1</sup>/<sub>8</sub>-inch Centers, One Drain/Vent Valve.

(Process Connection Code X and Option Code R2)

#### Stainless Steel Coplanar Flange with <sup>1</sup>/<sub>4</sub>-18 NPT on 2<sup>1</sup>/<sub>8</sub>-inch Centers, Two Drain/Vent Valves.

(Process Connection Code X and Option Code R3)

#### Stainless Steel Coplanar Flange with <sup>1</sup>/<sub>2</sub>-14 NPT on 2<sup>1</sup>/<sub>8</sub>-inch Centers, Two Drain/Vent Valves.

(Process Connection Code X and Option Code R4)

### Remote Seal

Process Connection Code X and Option Code S1)

Refer to Model 1199 Remote Seals Product Data Sheet PDS 4016

### Process Wetted Parts

#### Isolating Diaphragms

316 SST, Hastelloy C-276, or Monel

#### Drain/Vent Valves

316 SST or Hastelloy C-276

#### Wetted O-rings

Glass-filled Teflon<sup>®</sup>

### Non-Wetted Parts

#### Electronics Housing

Low-copper aluminum. NEMA 4X, IP 65

#### Bolts

Austenitic 316 SST (Standard with Process Connection Code A, B, E, F, M, or N, otherwise use L4 option); or plated carbon steel per ASTM A449, Grade 5.

#### Fill Fluid

Silicone or inert oil

#### Paint

Polyurethane

#### Cover O-rings

Buna-N

### Weight

Transmitter approximately 4.4 lb (2 kg) without options. See Table 1 for option weights.

## Product Data Sheet

00813-0100-4635, Rev CA

Catalog 2002 – 2003

# Model 3001C

TABLE 1. Flange Option Weights

Code	Option	Add lb (kg)
A	2-inch ANSI Class 150 Flange– Stainless Steel	7.8 (3.5)
B	2-inch ANSI Class 300 Flange– Stainless Steel	9.1 (4.1)
E	DIN DN50 PN 40	8.3 (3.8)
F	DIN DN80 PN 40	13.7 (6.2)
M	3-inch ANSI Class 150 Flange– Stainless Steel	13.2 (6.0)
N	3-inch ANSI Class 300 Flange– Stainless Steel	18.2 (8.3)
B4	SST Mounting Bracket for Coplanar Flange	1.0 (0.5)
G1	3-inch ANSI Class 150 Flange– Carbon Steel	10.7 (4.8)
G2	3-inch ANSI Class 300 Flange–Carbon Steel	15.5 (7.0)
R1	Coplanar Flange, One Drain/Vent Valve	1.9 (0.9)
R2	Coplanar Flange with <sup>1</sup> / <sub>2</sub> –14 NPT Adapters, One Drain/Vent Valve	3.2 (1.4)
R3	Coplanar Flange, Two Drain/Vent Valves	1.9 (0.9)
R4	Coplanar Flange with <sup>1</sup> / <sub>2</sub> –14 NPT Adapters, Two Drain/Vent Valves	3.2 (1.4)

## Hazardous Locations Certifications

### Factory Mutual (FM) Approvals

- E5** Explosion Proof for Class I, Division 1, Groups B, C, and D. Dust-ignition Proof for Class II, Division 1, Groups E, F, and G. Suitable for Class III, Division 1, indoor and outdoor (NEMA 4X) hazardous locations.
- I5** Intrinsically safe for use in Class I, Division 1, Groups A, B, C, and D; Class II, Division 1, Groups E, F, and G; Class III, Division 1 when connected in accordance with Rosemount drawings 03031-1019 and 00268-0031. Temperature Code T4 ( $T_a = 40^\circ\text{C}$ ), T3 ( $T_a = 85^\circ\text{C}$ ). Nonincendive for Class I, Division 2, Groups A, B, C, and D.

### Canadian Standards Association (CSA) Approvals

- C6** Explosion Proof for Class I, Division 1, Groups B, C, and D. Dust-ignition Proof for Class II, Division 1, Groups E, F, and G. Suitable for Class III, indoor and outdoor hazardous locations, CSA enclosure 4; factory sealed. Approved for Class I, Division 2, Groups A, B, C, and D.
- Intrinsically Safe for Class I, Division 1, Groups A, B, C, and D when connected in accordance with Rosemount drawing 03031-1024. Temperature Code T3C.

### BASEEFA/CENELEC Intrinsic Safety Certification

- I1** EEx ia IIC T5 ( $T_{amb} = 40^\circ\text{C}$ )  
EEx ia IIC T4 ( $T_{amb} = 70^\circ\text{C}$ )

### BASEEFA Type N Certification

- N1** EEx N IIC T5 ( $T_{amb} = 70^\circ\text{C}$ )

### CESI/CENELEC Flameproof Approval

- E8** EEx d IIC T6  
EEx d IIC T5 ( $T_{amb} = 70^\circ\text{C}$ )

### Japanese Industrial Standard (JIS) Flameproof Certification

- E4** Ex s d IIC T5 ( $T_{amb} = 60^\circ\text{C}$ )

### Standards Association of Australia (SAA) Approvals

- I7** Ex ia IIC T6, Class I, Zone 0  
**E7** Ex d IIC T6, Class I, Zone 1

## Dimensional Drawings

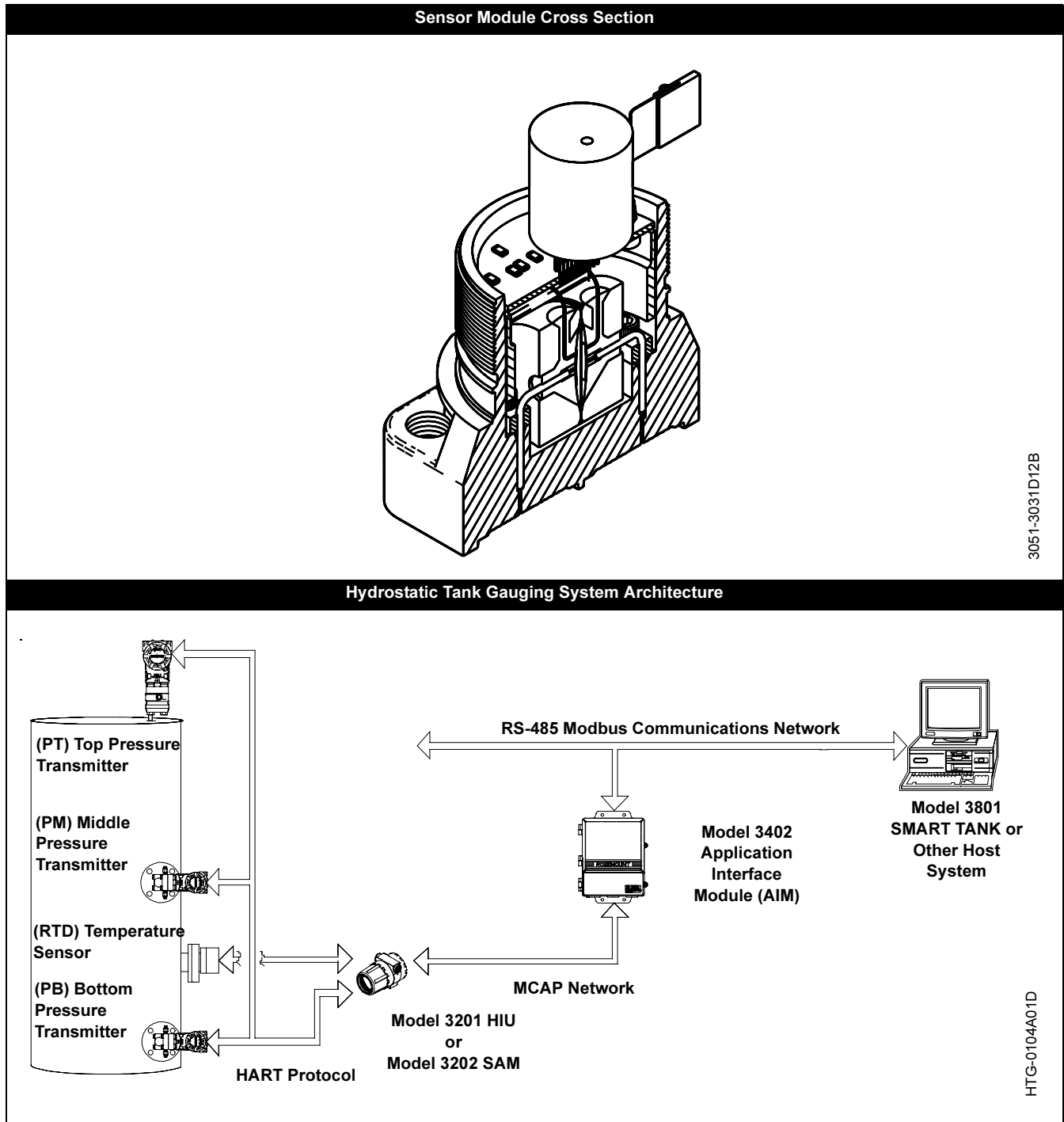

**Model 3001C Dimensional Drawing with Standard Flanged (2-inch Class 150) Process Connection**

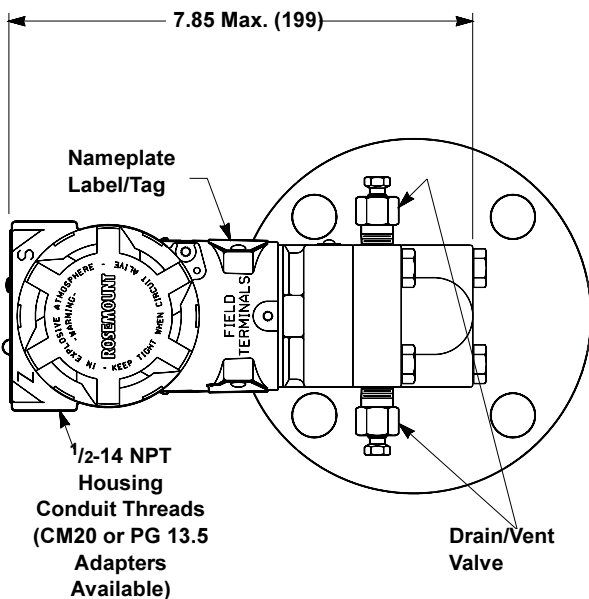
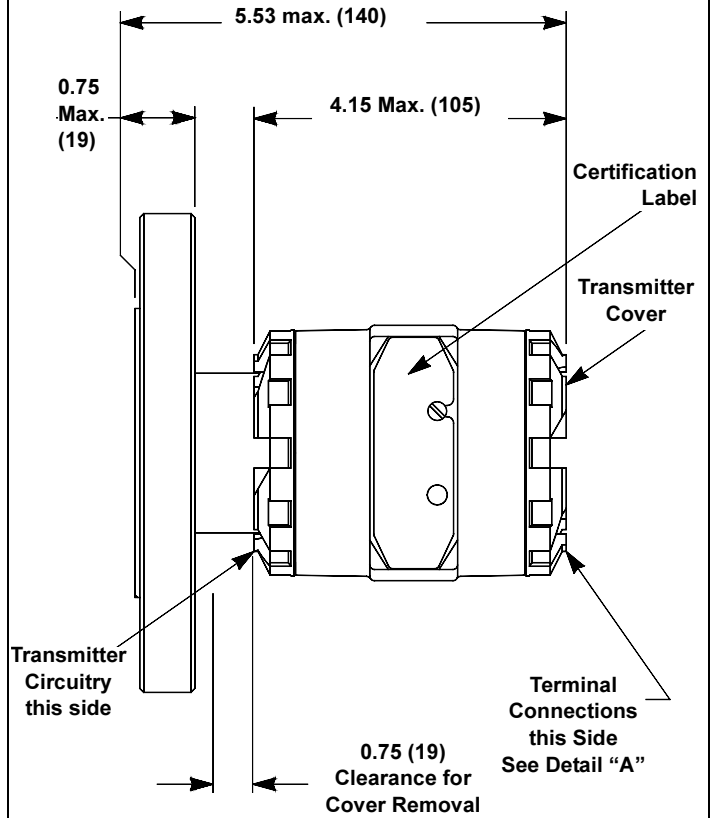
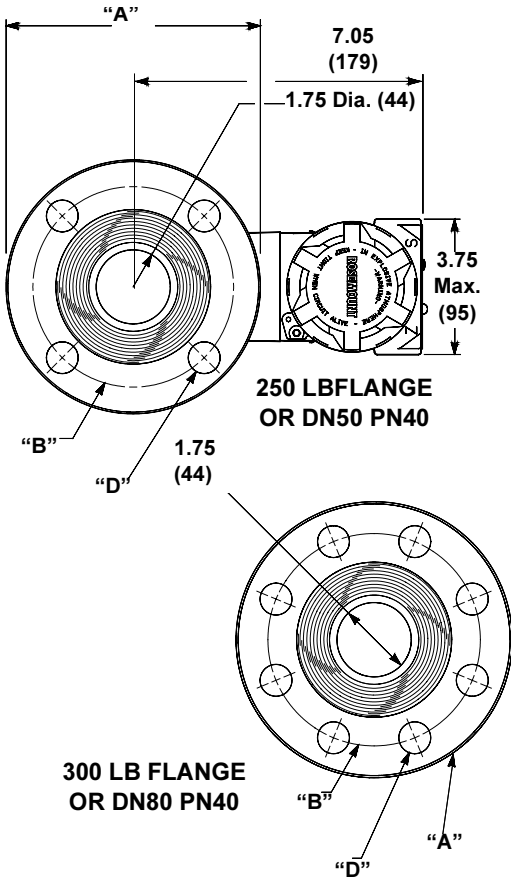

**DETAIL "A"  
 WIRING CONNECTIONS**

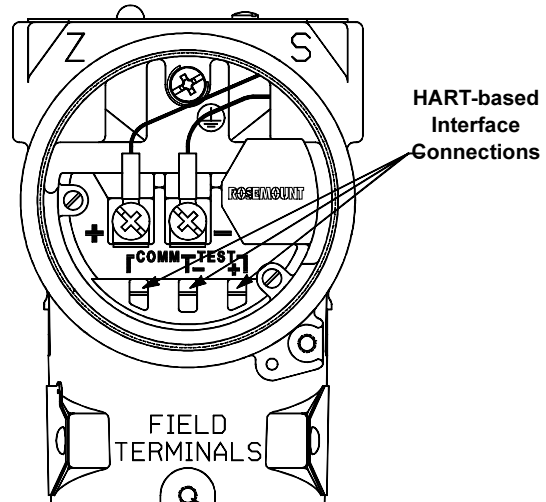

3001-3001C02B, 1009Z02A, 3001A02B, B02A, D02A

# Model 3001C

TABLE 2. Model 3001C Dimensions with Standard Flanged (2-inch Class 150) Process Connection

Flange	Flange Dia. "B"	Dia. "C"	Number of Bolt Holes	Hole Center "D"	Sealing Surface "E"
2-inch Class 150	6.00 (150)	0.75 (19)	4	4.75 (121)	3.62 (92)
2-inch Class 300	6.50 (165)	0.75 (19)	8	5.00 (127)	3.62 (92)
3-inch Class 150	7.50 (191)	0.75 (19)	4	6.00 (152)	5.00 (127)
3-inch Class 300	8.25 (210)	0.88 (22)	8	6.62 (168)	5.00 (127)
DIN DN50 PN40	6.50 (165)	0.71 (18)	4	4.92 (125)	0.79 (20)
DIN DN80 PN40	7.87 (200)	0.71 (18)	8	6.30 (160)	0.95 (24)

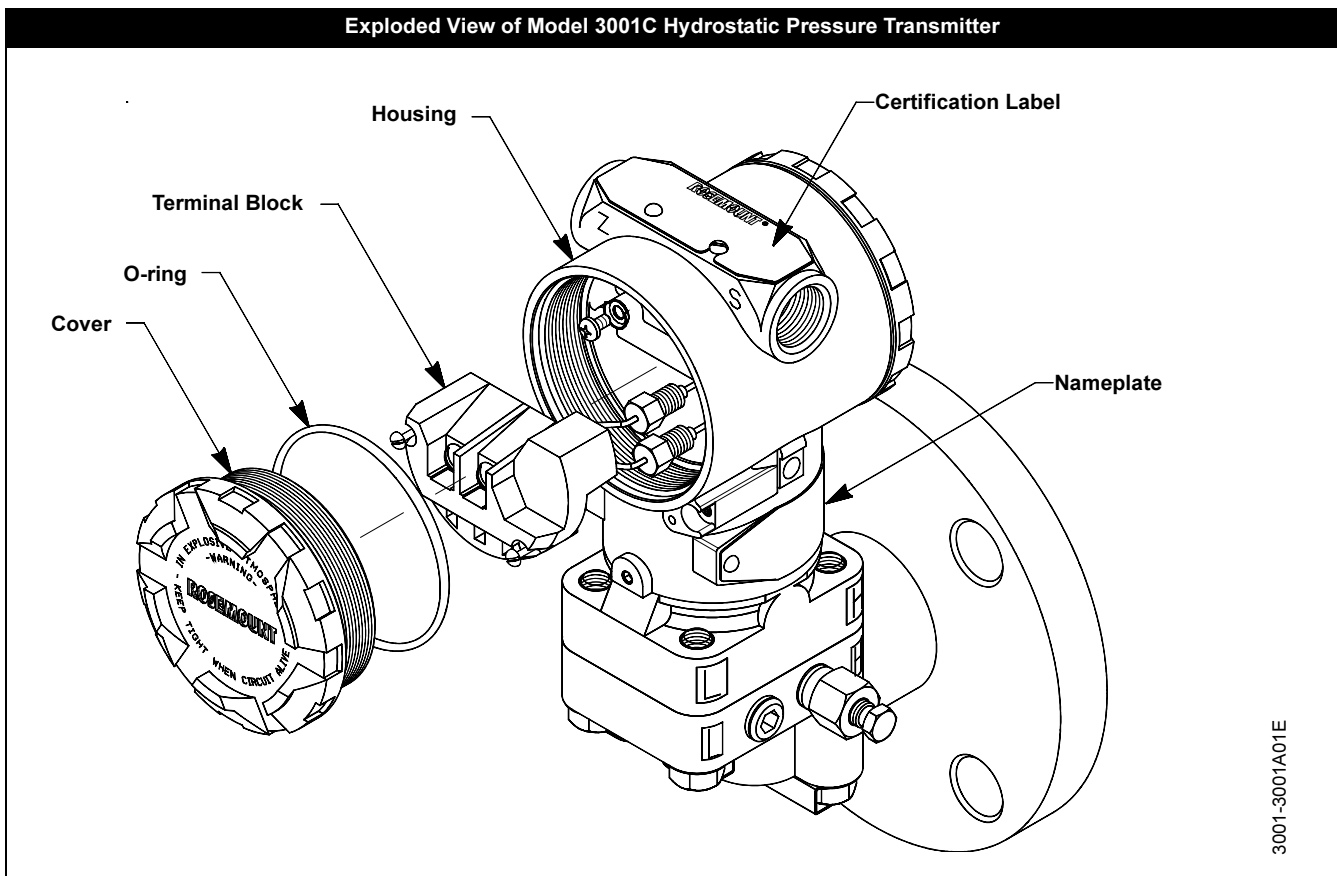

## Ordering Information

Mode	Product Description
3001C	Hydrostatic Pressure Transmitter
Code	Ranges
2	0–9 psig (0–62 kPa)
3	0–30 psig (0–207 kPa)
4	0–150 psig (0–1 040 kPa)
Code	Output
A	Digital signal based <i>HART</i> protocol
Code	Drain/Vent
2	316 SST
3	Hastelloy C
X	(Use when ordering an alternate process connection flange)
Code	Isolating Diaphragm
2	316 SST
3	Hastelloy C
4	Monel
Code	Process Connection
A	2-inch ANSI class 150 flange – stainless steel
B	2-inch ANSI class 300 flange – stainless steel
M	3-inch ANSI class 150 flange – stainless steel
N	3-inch ANSI class 300 flange – stainless steel
E	DIN DN50 PN-40 – stainless steel
F	DIN DN80 PN-40 – stainless steel
X	Alternate process flange—see options S1, R1, R2, R3, R4, G1, or G2
Code	Fill Fluid
1	Silicone
2	Inert
Code	Housing Conduit Thread
A	$\frac{1}{2}$ –14 NPT
B	CM 20 (via adapters)
C	PG 13.5 (via adapters)

Continued On Next Page

# Model 3001C

Code	Options
E5	Factory Mutual (FM) Explosion-Proof Approval
I5	Factory Mutual (FM) Non-incendive and Intrinsic Safety Approval
C6	Canadian Standards Association (CSA) Explosion-proof and Intrinsic Safety Approval (requires 42.4 V dc max. power supply)
I1	BASEEFA/CENELEC Intrinsic Safety Certification
N1	BASEEFA Type N Certification
E4	Japanese Industrial Standards (JIS) Flameproof Certification
I7	Standards Association of Australia (SAA) Intrinsic Safety Certification
E7	Standards Association of Australia (SAA) Flameproof Safety Certification
E8	CESI/CENELEC Flameproof Certification
L4	Austenitic 316 SST Bolts (standard with Flange Options A, B, M, and N)
A1	Analog Output
B4	SST Mounting Bracket with SST Bolts <sup>(1)</sup>
S1	One Remote Seal <sup>(2)</sup>
R1	Coplanar Flange, One Drain/Vent Valve
R2	Coplanar Flange with 1/2-14 NPT Adapters, One Drain/Vent Valve
R3	Coplanar Flange, Two Drain/Vent Valves
R4	Coplanar Flange with 1/2-14 NPT Adapters, Two Drain/Vent Valves
G1	3-inch ANSI Class 150 Flange—Carbon Steel
G2	3-inch ANSI Class 300 Flange—Carbon Steel
Q4	Calibration Data Sheet
Q8	Material Traceability Certification per EN102043.IB
T1	Transient Protection Terminal Block
J0022	0–18 psig (0–124 kPa) Range

**Typical Model Number: 3001C 3 A 2 2 A 1 A E5**  
**3001C 2 A X 3 X 1 A R1 B4**

(1) For use with Option Codes R1, R2, R3, or R4.

(2) See PDS 4016 for Remote Seal ordering information.

## HTG Product Data Sheets

### Hydrostatic Tank Gauging

00813-0100-4635	Model 3001C Hydrostatic Pressure Transmitter
00813-0100-4638	Model 3001CL Flush Mount Hydrostatic Pressure Transmitter
00813-0100-4640	Model 3201 Hydrostatic Interface Unit
00813-0100-4641	Model 3402 Application Interface Module
00813-0100-4646	Model 3202 Smart Application Module
00813-0100-4702	Model 3001CH Hydrostatic Pressure Transmitter for High Process Temperatures

### SMART FAMILY Companion Products

00813-0100-4275	HART Communicator
-----------------	-------------------



## Product Data Sheet

00813-0100-4635, Rev CA  
Catalog 2002 – 2003

# Model 3001C

---

*Rosemount and the Rosemount logotype are registered trademarks of Rosemount Inc.  
PlantWeb is a mark of one of the Emerson Process Management companies.  
All other marks are the property of their respective owners.  
Cover Photo: 3001\_001AB.tif*

### Emerson Process Management

**Rosemount Inc.**

8200 Market Boulevard  
Chanhassen, MN 55317 USA  
T 1-800-999-9307  
T (International) (952) 906-8888  
F (952) 949-7001

[www.rosemount.com](http://www.rosemount.com)

**Fisher-Rosemount**

Argelsrieder Feld 7  
82234 Wessling  
Germany  
Tel 49 (8153) 270  
Fax 49 (8153) 27172

**Fisher-Rosemount**

Singapore Pte Ltd.  
1 Pandan Crescent  
Singapore 128461  
Tel (65) 777-8211  
Fax (65) 777-0947  
[AP.RMT-Specialist@emersonprocess.com](mailto:AP.RMT-Specialist@emersonprocess.com)