

Model 470 Transient Protector



Model 470 Transient Protector

NOTICE

Read this manual before working with the product. For personal and system safety, and for optimum product performance, make sure you thoroughly understand the contents before installing, using, or maintaining this product.

Within the United States, Rosemount Inc. has two toll-free assistance numbers:

Customer Central

Technical support, quoting, and order-related questions.

1-800-999-9307 (7:00 am to 7:00 pm CST)

North American Response Center

Equipment service needs.

1-800-654-7768 (24 hours—includes Canada)

Outside of the United States, contact your local Rosemount representative.

⚠ CAUTION

The products described in this document are NOT designed for nuclear-qualified applications. Using non-nuclear qualified products in applications that require nuclear-qualified hardware or products may cause inaccurate readings.

For information on Rosemount nuclear-qualified products, contact your local Rosemount Sales Representative.

Table of Contents

SECTION 1 Introduction	Overview of Manual	1-1
SECTION 2 Installation	Installation Procedure Cathodic Protection	2-2 2-3
SECTION 3 Operation	Operation	3-1
SECTION 4 Hardware and Software Maintenance and Troubleshooting	Return of Material	4-1
APPENDIX A Reference Data	470D and 470C Transient Protector 470L and 470J Transient Protector Hazardous Locations Certifications Dimensional Drawing Ordering Information	A-1 A-2 A-2 A-3 A-3

Model 470

Reference Manual
00809-0100-4191, Rev BA
8/16/01

Section 1 Introduction

OVERVIEW OF MANUAL

The Rosemount® Model 470 Transient Protector prevents s damage from transients induced by lightning, welding, heavy electrical equipment, or switch gears. The Model 470 continues to protect transmitters even after repeated strikes of up to 5,000 amps. In laboratory simulated lightning tests, the Model 470 withstood 2,000 amps or 10,000 volts without damage to either the transient protector or the transmitter.

Models 470D and 470C are designed to protect two-wire transmitters that are capable of withstanding 120 volts from lead to case, and can also be used to protect the receiver or RTU. Models 470L and 470J are designed to protect low power or other three-wire transmitters.

The weatherproof, stainless steel-cased protector functions under severe environmental conditions including high temperature and humidity.

Section 2 Installation

Installation Procedure	page 2-2
Cathodic Protection	page 2-3

The circuitry of the Model 470 Transient Protector is potted in a 1/2 in. stainless steel pipe nipple. The protector can be installed in a 100% humidity, -40 to 212°F (-40 to 100°C) environment. A bypass wire and two clamps are provided to electrically bond the case of the protector to the case of the instrument being protected.

Figure 2-1 and 2-2 show the wiring diagram of a typical installation consisting of a two-wire transmitter, a power supply, a receiver, and two transient protectors. Figure 2-3 and 2-4 show the wiring diagram for a typical installation with a three-wire transmitter.

The following installation considerations should be deliberated before proceeding:

- The bypass wire ensures a low resistance path between the protector case and the transmitter case.
- The transmitter case is to be well-grounded to provide a low-impedance path to ground (unless cathodic protection is used).
- To provide protection for receiving equipment, install an additional protector at a point where field wiring enters the building. The amount of protection provided by a protector located at this point is critically dependent upon the adequacy of the ground connection.
- If the power supply (45 V dc maximum) is capable of delivering more than 0.5 amps short circuit current, use a limiting resistor (47 ohms minimum, 1/2 watt, carbon composition) to prevent continuous conduction by the protector after a transient occurs.

INSTALLATION PROCEDURE

Step 1:

Locate the end of the protector marked "transmitter leads," and screw this end of the protector into the conduit connection of the transmitter housing. Attach the lead wires as shown in Figure 2-1, 2-2, 2-3, and 2-4.

Step 2:

At the "field leads" end of the protector, connect the lead wires as shown in Figure 2-1, 2-2, 2-3, and 2-4.

Step 3:

Locate a point on the transmitter housing to connect the bypass wire. Thoroughly clean all dirt, grease, paint, or other coatings from the surface of the protector and from the point of connection on the transmitter housing.

Using stainless steel clamps, attach the bypass wire firmly. Keep the bypass wire as short and straight as possible. This lead must be connected even in installations that use a separate case connection lead (green lead). The bypass wire is clad with nickel and sealed at both ends for corrosion protection, therefore do not cut excess wire. Avoid connections to aluminum, as galvanic corrosion may result.

Step 4:

Important: The protector case as well as all equipment attached to the protector must be electrically grounded and bonded in strict accordance with articles 250 and 280 of the National Electrical Code (ANSI C2-1977) and the Lightning Protection Code (NFPA 78-1968; ANSI C5.1-1969) and Section 9 of the National Electric Safety Code (ANSI C2-1984).

Step 5:

When a transient protector is used to protect receiving equipment located in a control room, bond the protector to a well-established earth ground.

Step 6:

In a typical two-wire transmitter installation, the loop resistance added by the Model 470C or 470D (20 ohms per loop) should have no effect on operation.

In a three-wire system, however, the voltage signal measured by the receiver is affected by the voltage drop across the common (brown) lead. The resistance added by the Model 470L or 470J (1 ohm maximum per lead) may have a measurable effect on measured output. In this instance, the transmitter should be recalibrated with the protector connected.

CATHODIC PROTECTION

If cathodic protection is used, the transmitter case and protector case are deliberately kept negative with respect to earth ground. Direct grounding of the case or associated piping per the electrical codes would defeat cathodic protection. In this case, the electrical transient current should be diverted to ground across the cathodic protection power supply with a suitable lightning arrestor. The green case grounding lead on Models 470C or 470J can not be connected without defeating cathodic protection.

Figure 2-1. Installation Schematic for Two-wire Transmitter and Control Room Equipment Using Two Model 470D Transient Protectors

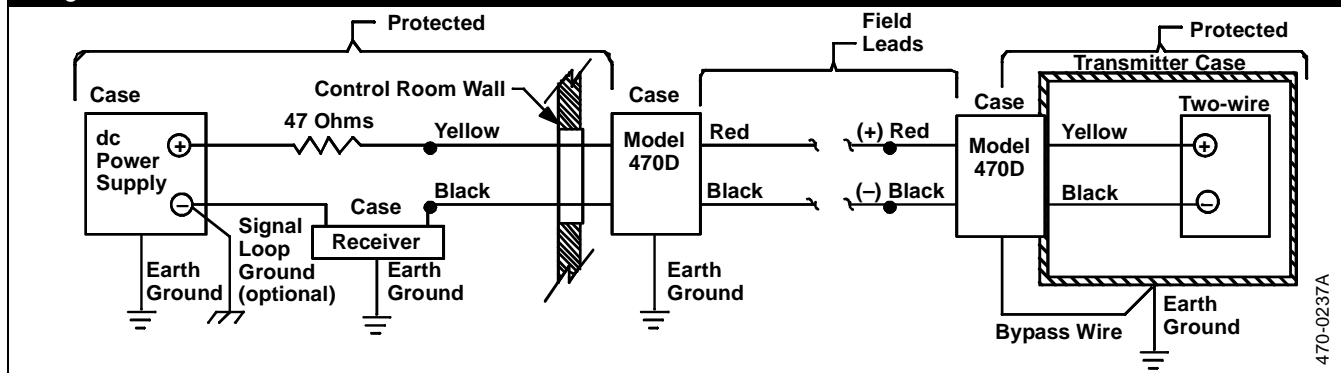

470-0237A

Figure 2-2. Installation Schematic for Two-wire Transmitter and Control Room Equipment Using Two Model 470C Transient Protectors

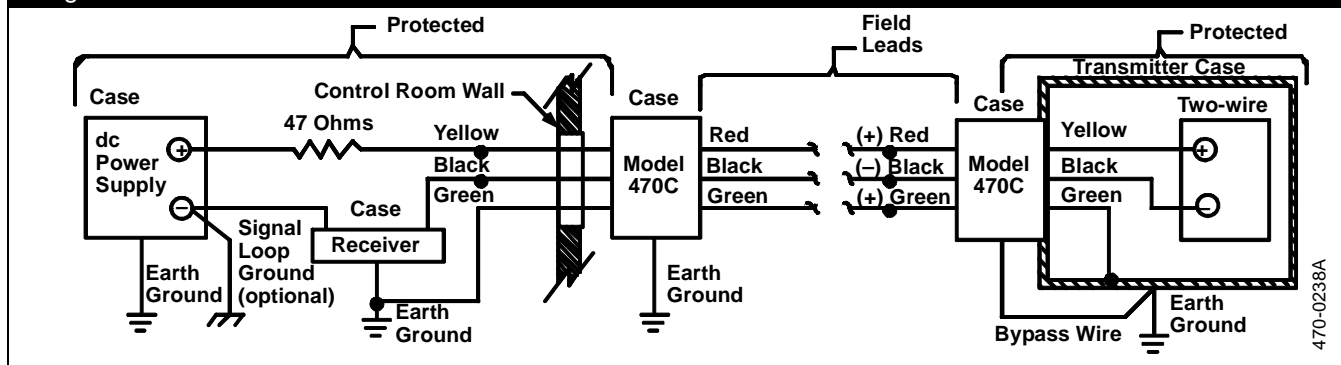

470-0238A

Model 470

Figure 2-3. Installation Schematic for Three-wire Transmitter and Control Room Equipment Using Two Model 470L Transient Protectors

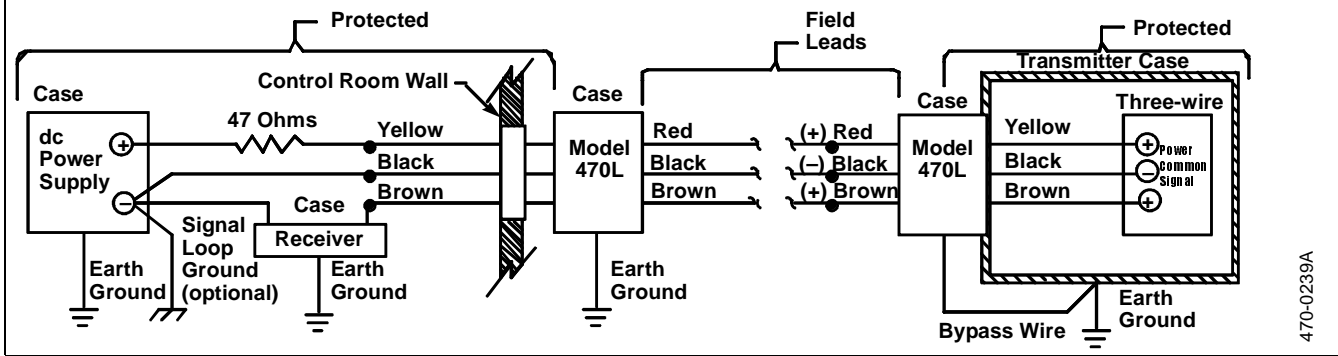

Section 3 Operation

The Model 470 Transient Protector is designed to protect two- and three-wire current transmitters or similar dc equipment from damage due to high energy transients induced into field wiring by nearby lightning strikes or by transients in adjacent wiring. It can be used to protect any current or voltage signal equipment, subject to the following requirements:

- The dc voltage between leadwires and from either leadwires and from either leadwire to ground should not exceed 45 V dc nominal (48 V dc maximum).
- The protected equipment can withstand 120 volts peak with respect to ground.

WARNING

This protector is intended to protect only the instrument being bypassed, and is not a safety device. To prevent damage or injury to other equipment or to personnel in event of a nearby lightning strike, the equipment to which the protector is bypassed must be well-grounded in accordance with the National Electrical Code (ANSI C2-1977), the Lightning Protection Code (NFPA 78-1968; ANSI C5.1-1969), and Section 9 of the National Electric Safety Code (ANSI C2-1984).

The protector circuits are shown in Figure 3-1.

OPERATION

The Rosemount Model 470 Transient Protector consists of separate circuits—one for each lead wire (excluding the green ground wire) epoxy-sealed inside a 1/2–14 NPT stainless steel pipe nipple for direct mounting to a transmitter. Each signal lead uses an identical protector circuit consisting of a gas-filled spark gap, an inductor, and a fast-response bipolar zener diode.

A high-voltage transient appearing on any field signal wire is conducted to the case through the gas-filled spark gap. This device conducts large currents, but has a slow reaction time. The fast-rising portion of the transient is conducted to the case through the zener diode, which has a fast reaction time. The inductor limits the diode current during the time required for the spark gap to conduct.

The bypass wire connected between the protector case and instrument case ensures that both remain at the same potential, thus preventing dielectric breakdown inside the protected device.

Once the spark gap has begun to conduct, it will continue to do so unless the instrument power supply limits current to 0.5 amps or less. A 47-ohm quenching resistor can be added to prevent conduction after the transient has discharged.

The green lead used in the Model 470C or 470J is connected directly to the protector case, and is used only in those instances where a separate instrument case ground is desired. It cannot be used to replace the bypass wire, and cannot be used in cathodically protected installations.

Figure 3-1. Schematic Diagram

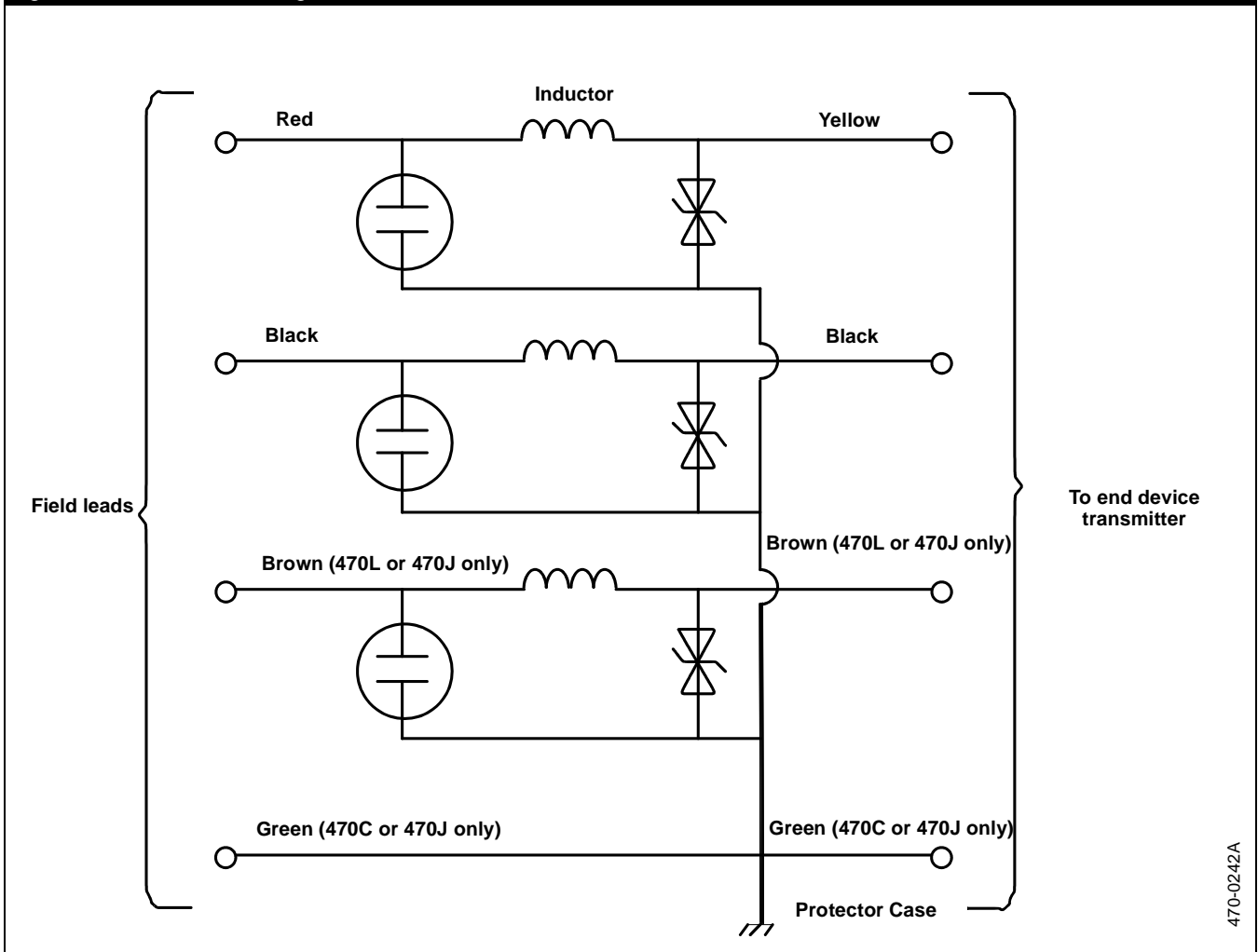

Section 4 Hardware and Software Maintenance and Troubleshooting

The transient protector is non-repairable. Maintenance is limited to a periodic inspection of the condition of the grounding and bypass wiring.

An ohmmeter which will not provide more than 45 volts across the measuring terminals is required to determine if a protector is operational. Disconnect all leadwires and measure the following resistance:

1. Red to Yellow - 10 ohms or less
2. Black to Black - 10 ohms or less
3. Brown to Brown - 10 ohms or less
4. Green to Green - 1 ohms or less
5. Any signal leadwire to case - greater than 1 megohm
6. Green lead to case - 1 ohm or less

Failure to obtain these readings is justification to replace the protector.

RETURN OF MATERIAL

To expedite the return process, call the Rosemount North American Response Center at 800-654-RSMT (7768) toll-free number. This center, available 24 hours a day, will assist you with any needed information or materials.

The center will ask for product model and serial numbers, and will provide a Return Material Authorization (RMA) number. The center will also ask for the name of the process material to which the product was last exposed.

CAUTION

People who handle products exposed to a hazardous substance can avoid injury if they are informed and understand the hazard. If the product being returned was exposed to a hazardous substance as defined by OSHA, a copy of the required Material Safety Data Sheet (MSDS) for each hazardous substance identified must be included with the returned goods.

The Rosemount North American Response Center will detail the additional information and procedures necessary to return goods exposed to hazardous substances.

Appendix A Reference Data

470D and 470C Transient Protector	page A-1
470L and 470J Transient Protector	page A-2
Hazardous Locations Certifications	page A-2
Dimensional Drawing	page A-3
Ordering Information	page A-3

Temperature Limits
–40 to 212 °F (–40 to 100 °C)

Humidity Limits
0 to 100% relative humidity

Maximum Clamping Voltage
Any lead to case⁽¹⁾

dc
68 V

100 kV/microsecond surge
70 V peak

1,000 kV/microsecond surge
120 V peak

Transient Surge Current⁽¹⁾
Up to 5,000 amps for 20 microseconds—repeated strikes

470D AND 470C TRANSIENT PROTECTOR

Transmitter Output Compatibility
4–20 mA

Transmitter Power Supply
45 V dc maximum

Loop Resistance Added by Protector⁽¹⁾
20 ohms maximum

(1) Tested under reference operating conditions.

Model 470

470L AND 470J TRANSIENT PROTECTOR

Transmitter Output Compatibility

4–20 mA (regular power)
0.8 to 3.2 V (low power)
1.0 to 5.0 V (low power)

Transmitter Power Supply

45 V dc maximum, 5 V dc minimum

Loop Resistance Added by Protector⁽¹⁾

1 ohm per lead maximum

HAZARDOUS LOCATIONS CERTIFICATIONS

Canadian Standards Association (CSA) Approvals

- E6** Explosion proof for Class I, Division 1, Groups C and D; Dust-Ignition Proof Class II, Division 1, Groups E, F, and G; Dust-Ignition Proof Class III, Division 1 hazardous locations; Suitable for Class I Division 2 Groups A, B, C, and D. CSA Enclosure Type 4. Factory Sealed.
- I6** Intrinsic Safety for Class I, Division 1, Groups A, B, C, and D. Intrinsic safety approval only when used with the barrier parameter in Table A-1. CSA Enclosure 4.

Centro Elettrotecnico Sperimentale Italiano (CESI/CENELEC) Certification

- C8** Flameproof Approval:
EEx d IIC T6
Intrinsic Safety Approval:
EEx ia IIC T6

 $U_{max} = 45 \text{ V}$
 $C_{eq} = 1 \text{ nF}$
 $L_{eq} = 1 \text{ mH}$

Table A-1. CSA Entity Approvals

Barrier Manufacturer/Model	CSA Approved for Class 1, Division 1, Groups			
	A	B	C	D
Any CSA approved zener barrier $\leq 30 \text{ V}, \geq 330 \Omega$ or $\leq 28 \text{ V}, \geq 300 \Omega$ or $\leq 22 \text{ V}, \geq 180 \Omega$	•	•	•	•
Foxboro Converters 2AI-I2V-CGB, 2AI-I3V-CGB 2AS-I3I-CGB, 2AS-I2I-CGB 3AD-I3IA-CS-E / CGB-A 3A2-I2D-CS-E / CGB-A 3A2-I3D-CS-E / CGB-A 3A4-I2DA-CS-E / CGB-A 3F4-I2DA1-CS-E / CGB-A	NA	•	•	•

(1) Tested under reference operating conditions.

**DIMENSIONAL
 DRAWING**

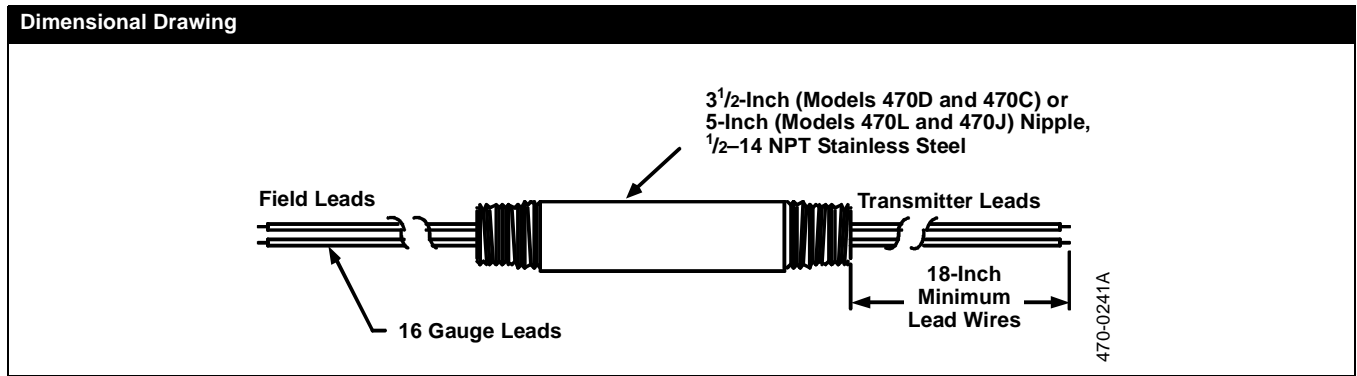

**ORDERING
 INFORMATION**

Model	Product Description	Nipple Length
470D	Transient Protector	3½-inch
470C	Transient Protector (CSA Approved Unit)	3½-inch
470L	Transient Protector – Low Power	5-inch
470J	Transient Protector – Low Power (CSA Approved Unit)	5-inch
Code	Loop Resistance	Maximum Supply Voltage
1	20 Ohms (Models 470D, 470C)	45 V
1	1 Ohm per Lead, Max. (Models 470L, 470J)	45 V
Code	Options	
NA	No Approval Required	
E6	Canadian Standards Association (CSA) Explosion-Proof Approval (Models 470C, 470J only)	
I6	Canadian Standards Association (CSA) Intrinsic Safety Approval (Models 470C, 470J only)	
C8	Centro Elettrotecnico Sperimentale Italiano (CESI/CENELEC) Flameproof and Intrinsic Safety Certifications (Models 470D, 470L only)	
Typical Model Number: 470D 1 NA		

Reference Manual

00809-0100-4191, Rev BA

August 2001

Model 470

*Rosemount and the Rosemount logotype are registered trademarks of Rosemount Inc.
PlantWeb is a mark of one of the Emerson Process Management companies.
All other marks are the property of their respective owners.*

Cover Photo: 470-470-002ab.tif

Emerson Process Management

Rosemount Inc.

8200 Market Boulevard
Chanhassen, MN 55317 USA
T 1-800-999-9307
F (952) 949-7001

www.rosemount.com

