

Models 1080 and 1082 Multipoint Thermocouple and RTD Profiling Sensors

BEST INSTALLATION PRACTICES

- *Efficient way of monitoring a temperature profile for a wide range of applications, especially hot-spot detection*
- *Compact design of independent measurement points. Up to 60 points within an insert tube diameter of 8 mm (0.32 inch)*
- *Low cost per measurement point*
- *Onsite replacement of individual elements*
- *Only one process connection for up to 60 independent measurement points*
- *A complete temperature measurement solution. The transmitter, enclosure, sensor and thermowell can be ordered as a complete assembly using one model number*



Content

Introduction	page 2
Product Overview	page 4
Model 1080C Thermocouple Multipoint Sensor–Compact Design	page 5
Specifications	page 5
Ordering Tables	page 7
Configuration Data Sheet (CDS)	page 9
Model 1080F Thermocouple Multipoint Sensor–Contacting Fixture Design	page 11
Specifications	page 12
Ordering Tables	page 14
Configuration Data Sheet (CDS)	page 16
Model 1082R RTD Multipoint Sensor–Contacting Fixture Design	page 18
Specifications	page 18
Ordering Tables	page 20
Configuration Data Sheet (CDS)	page 22
Multipoint Sensor Enclosures	page 24

Models 1080 and 1082

Introduction

Multipoint Temperature Profiling Sensors measure the temperature at different points along its length. These sensors are frequently used in chemical and petrochemical industries because they provide an excellent temperature profile for chemical reactors, catalytic crackers, and fractionation towers. For these applications, Multipoint Temperature Profiling Sensors are the most efficient cost, maintenance, and data acquisition solution. Multipoint Temperature Profiling Sensors allow, with a single pipe penetration, the reading of up to 60 points that can be evaluated to provide a complete temperature profile of the column, tank, or reactor.

TYPICAL APPLICATIONS

Reactors

Multipoint Temperature Profiling Sensors improve monitoring and control of the reaction process within chemical reactors.

One example of how Multipoint Temperature Profiling Sensors are used is in the production of organic acid. Many organic acids are produced through an exothermal oxidation process. This chemical reaction takes place in multiple tubes filled with catalyst. The reaction components flow into the tubes (process in), react together (due to the catalyst), and then flow out as an acid (process out). The tubes are cooled by a cooling fluid flowing around the tubes. A critical process parameter is the process temperature. A Multipoint Temperature Profiling Sensor, such as the compact design of the Model 1080C, measures the temperature profile inside a reaction tube. This temperature profile represents the profile of the other reaction tubes. Through monitoring the temperature profile the flow of reaction components and cooling fluid can be controlled to maximize the process output and reaction efficiency. A high local resolution of the temperature profile is required to ensure that the hot-spot (maximum measured temperature) does not reach the maximum allowable process temperature.

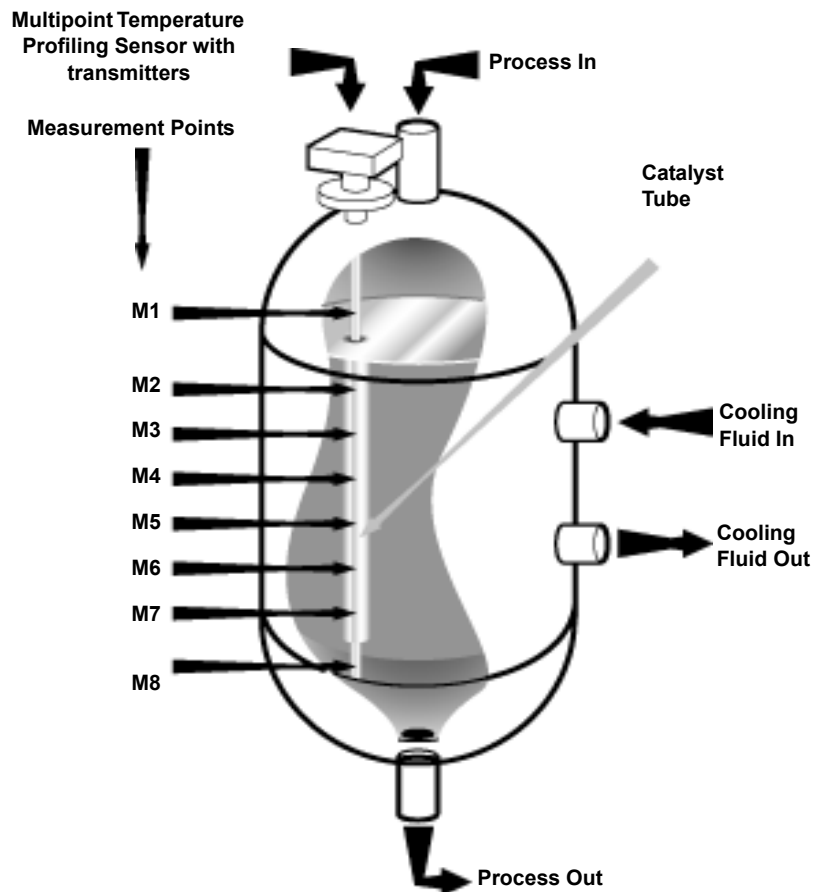

Product Data Sheet

00813-0100-4019, Rev BA

November 2002

Models 1080 and 1082

Distillation Columns / Fractionators

In a crude oil distillation process, crude oil is heated and run into a distillation column or fractionator, where a significant temperature profile can be measured (hot at the bottom, cooler at the top). Inside the column crude oil is separated into components or fractions according to weight and boiling point. As these component vapors travel up, they condense into liquid. The condensed components are captured by strategically mounted trays or “decks”. The trays are located at a height where the column temperature matches a components condensation point. The tray locations, or cut-points, are where products are then drawn from the column. Multipoint Temperature Profiling Sensors can be used to monitor the temperature at these cut-points and then control the temperature profile of the distillation column.

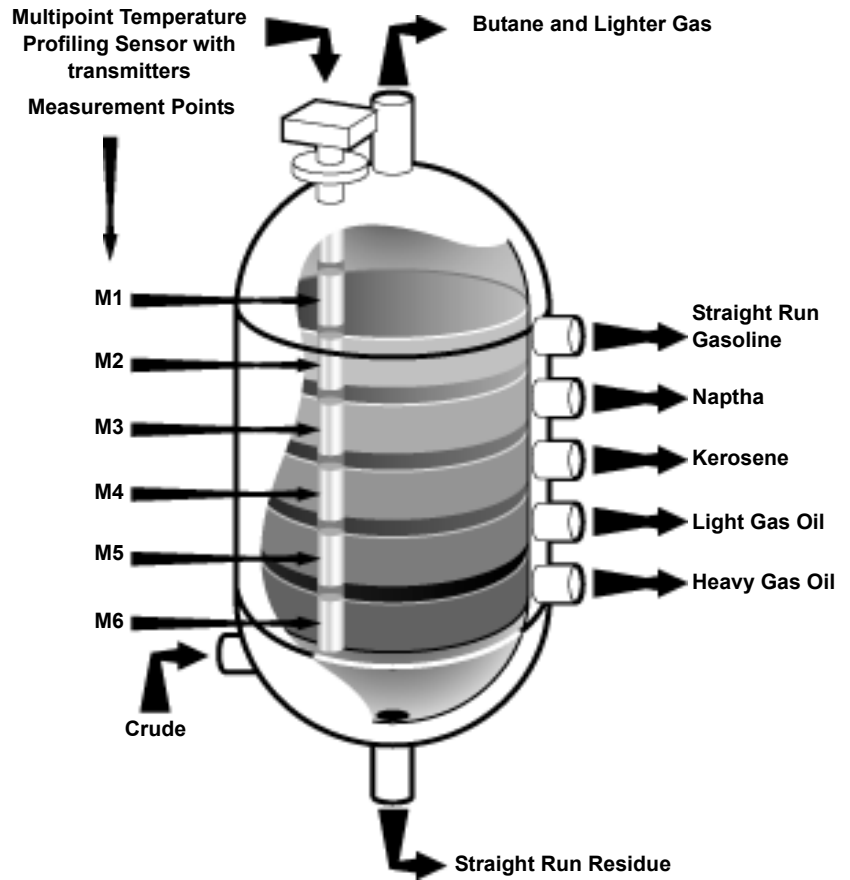

An Integrated Complete Solution

Each Multipoint Temperature Profiling Sensor can be used with integral mount temperature transmitters, allowing for a complete package solution for the monitoring of a temperature profile. Up to six Model 848T Temperature Transmitters with FOUNDATION™ fieldbus (8 independent measurement channels per Model 848T transmitter) or twenty-four head mount Model 644H Smart Temperature Transmitters (HART) or head mount Model 244EH PC-Programmable Temperature Transmitters can be mounted into one enclosure. This enclosure is then mounted on the top of the Multipoint Temperature Profiling Sensor. The transmitters can be configured by the factory to minimize start-up costs.

Model 848T



For product specifications see the Model 848T Product Data Sheet (document number 00813-0100-4697)

Model 644H



For product specifications see the Model 644 Product Data Sheet (document number 00813-0100-4728)

Model 244EH



For product specifications see the Model 244E Product Data Sheet (document number 00813-0100-4737)

Models 1080 and 1082

PRODUCT OVERVIEW

Multipoint Temperature Profiling Sensors can be used in almost any temperature profile application. The Models 1080 and 1082 sensors are constructed using durable mineral insulated (MI) cable and can be provided with thermocouples (type E, J, K, or N) or with Pt100 resistance elements (RTDs). Rosemount Inc. has provided model structures for each multipoint sensor base design. These model numbers are developed to make it easy to order a Rosemount® Multipoint Temperature Profiling Sensor. The model structures are constructed with flexibility; if a mounting option or thermowell material is not available in the ordering tables, this does not mean that Rosemount Inc. can not provide it. Consult the factory and use the Configuration Data Sheet (CDS) provided for each Multipoint Temperature Profiling Sensors model, and Rosemount Inc. will provide the sensor which will accommodate the process application.

The tables below provide a quick reference for the performance and physical aspects of the three base Multipoint Temperature Profiling Sensors designs, the Model 1080C (Compact), Model 1080F (Contacting Fixture), and Model 1082R (Contacting Fixture RTD).

TABLE 1. Performance Considerations

	Model 1080C	Model 1080F	Model 1082R
Measuring Element Type	E, J, K, or N Thermocouple	E, J, K, or N Thermocouple	Pt100 RTD
Number of Measurement Points	2 minimum, 60 maximum Highest local resolution	2 minimum, 20 maximum	2 minimum, 12 maximum
Temperature Range	-40 to 750 °C (-40 to 1382 °F)	-40 to 800 °C (-40 to 1472 °F)	-40 to 450 °C (-40 to 842 °F)
Response Time	<ul style="list-style-type: none"> Moderate, but depends on thermowell design used by the application 	<ul style="list-style-type: none"> Moderate, for Individual Guide Tube design Fast, for Laminated Spring design Fast, for Radial Spring design 	<ul style="list-style-type: none"> Moderate
Life Expectancy	Standard	High	High
Local High Resolution Temperature Profiling⁽¹⁾	Yes	No	No
Durability	Standard	High	High
Replaceable individual Elements?	No	<ul style="list-style-type: none"> Yes, for Individual Guide Tube design No, for Laminated and Radial Spring design 	No

(1) For identifying process fluid hot-spots

TABLE 2. Physical Considerations

	Model 1080C	Model 1080F	Model 1082R
Required Inner Diameter of Existing Process Thermowells⁽¹⁾	4 - 10 mm	≥ 25 mm	≥ 30 mm
Maximum Insertion Length	10m (33 ft) [30 m (99 ft) bundled version]	10m (33 ft) with thermowell [30 m (99 ft) without thermowell for Radial Spring and Laminated Spring designs only]	10m (33 ft) with thermowell [30 m (99 ft) without thermowell for Radial Spring design only]

(1) Depends on the number of measurement points

Model 1080C Thermocouple Multipoint Sensor - Compact Design

The Model 1080C is a compact Multipoint Sensor. The sensing elements are single ungrounded thermocouples. The high number of measurement points allow the monitoring of temperature profiles with a very good local resolution. The Model 1080C is often used

for

- hot-spot detection
- temperature profile monitoring

in

- tall reactors
- distillation columns.

The Model 1080C is delivered without a thermowell because the thermowell typically already exists at the installation site. If a thermowell is required, please contact Rosemount Inc. The Model 1080C is delivered either with an insert tube or in the bundled version (see Figure 2). The function of the insert tube is to fix the sensing elements and give mechanical stability to the sensor. The Model 1080C, with an insert tube, can be shipped up to a length of 10m (33ft) and cannot be coiled for shipping. The Model 1080C in the bundled version can be delivered up to a length of 30m (99 ft) and is shipped as a coil (see Figure 1).

FIGURE 1. Bundled Multipoint Sensor Coiled for Shipping

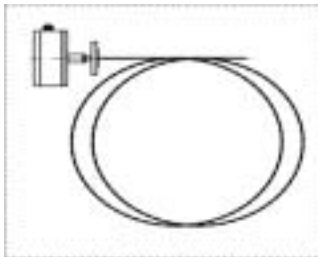

SPECIFICATIONS

Functional

Number of Measurement Points

2 to 60

Temperature Limits

-40 to 750 °C (-40 to 1382 °F)

Physical

Physical Dimensions

TABLE 3. Available Insert Tube Outer Diameters

Diameter		Maximum Measurement Points
mm	inch	
3.5	0.14	25
4.5	0.18	30
5.0	0.20	40
6.0	0.24	60
8.0	0.32	60

TABLE 4. Length Limits

With Insert Tube		Bundled Version	
m	ft	m	ft
10	33	30	99

Performance

Ambient Temperature Limits

For enclosures and transmitters is -40 to 80 °C (-40 to 176 °F)

Insulation Resistance

Greater than 1000 MOhm at room temperature. See Table for applied voltage.

TABLE 5. Applied Voltage for Insulation Resistance Measurement, based upon minerally insulated cable outside diameter

Outer Diameter		Test Voltage
mm	inch	
0.34	0.013	75 VDC
0.50	0.020	100 VDC
1.00	0.039	250 VDC

Accuracy

TABLE 6. Limits of Error Interchangeability for Class I Thermocouples

Type	
E	1.5 °C or 0.004 t (1), -40 to 750 °C
J	1.5 °C or 0.004 t (1), -40 to 750 °C
K	1.5 °C or 0.004 t (1), -40 to 750 °C
N	1.5 °C or 0.004 t (1), -40 to 750 °C

(1) Whichever is greater. "t" is in degrees Celsius

Enclosures

The enclosures are described in "Multipoint Sensor Enclosures" on page 24 and 25.

Individual Sensor Identification Data

By default, sensor 1 is closest to the flange. Remaining points are numbered incrementally. Use the C1 option and the CDS if a different numbering system is desired.

Models 1080 and 1082

FIGURE 2. Multipoint Sensor Model 1080C Compact Design

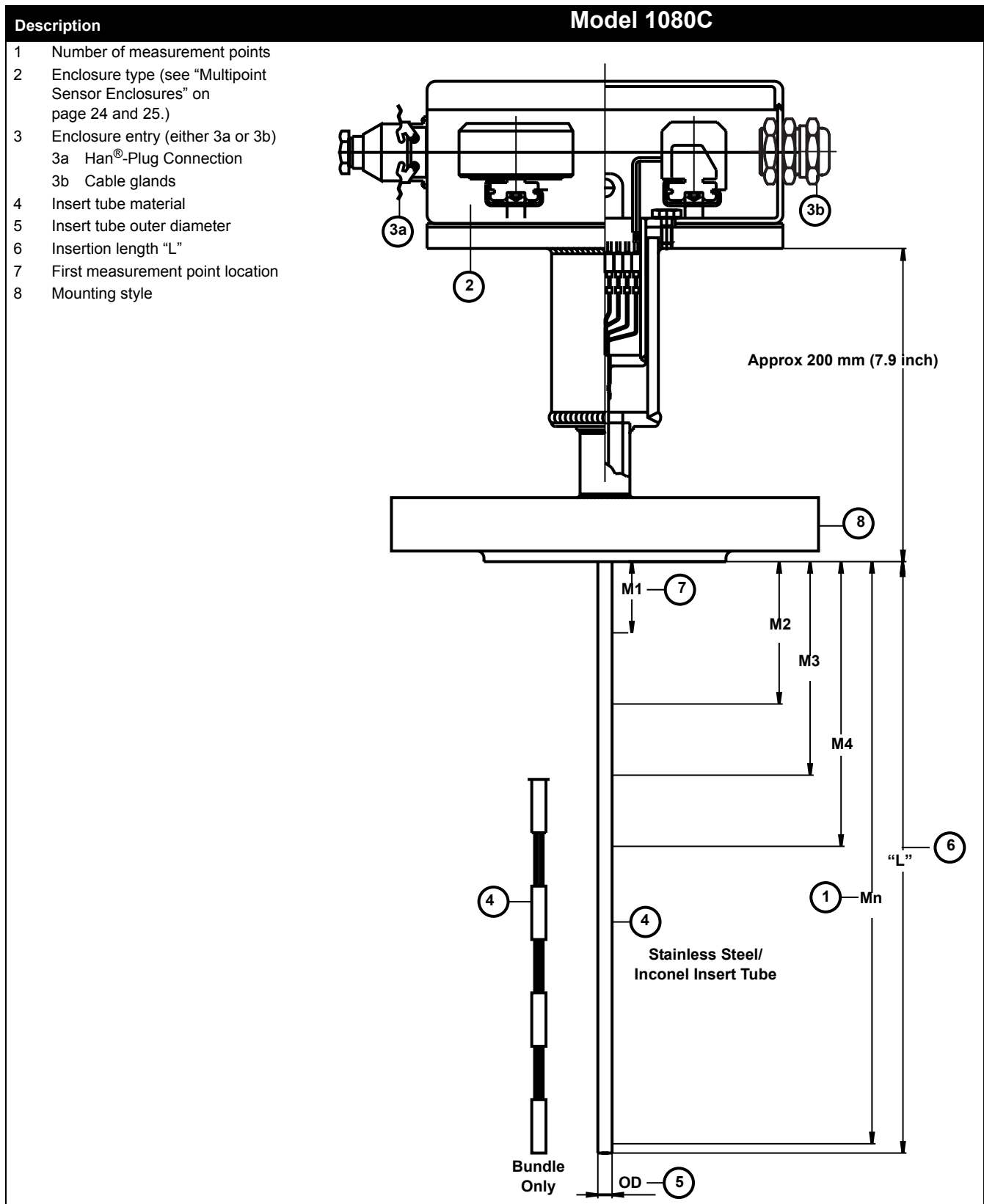

ORDERING INFORMATION– MODEL 1080C

Model	Product Description			
1080C	Series 1080C Thermocouple Multipoint Profiling Sensor - Compact Design - Tolerance Class 1			
Code	Thermocouple Type	Operating Temperature Range		
		°C	°F	
E1	E	-40 to 750	-40 to 1382	
J1	J	-40 to 750	-40 to 1382	
K1	K	-40 to 750	-40 to 1382	
N1	N	-40 to 750	-40 to 1382	
Code	Number of Measurement Points			
08	8			
16	16			
24	24			
32	32			
40	40			
48	48			
XX	Other Quantities (minimum. 02; maximum. 60)			
Code	Transmitter Type	Maximum Measurement Points		
A	Model 848T Temperature Transmitter–FOUNDATION™ fieldbus	48		
B	Model 644H Temperature Transmitter–HART®	24		
C	Model 244EH Temperature Transmitter–PC-Programmable	24		
N	No transmitter–Terminal strip only	60		
Code	Enclosure Type	Material	IP Rating	NEMA Rating
A	EEx d CENELEC Flameproof Approval (consult factory for availability)	Aluminum	65	NEMA 4
B	EEx e CENELEC Increased Safety Approval (consult factory for availability)	Aluminum	65	NEMA 4
C	EEx i Intrinsically Safety acc. EN 50014 and EN 50020 with manufacturer declaration for Ex i use in Zone 1	Aluminum	65	NEMA 4
D	Standard Aluminum	Aluminum	65	NEMA 4
E	Standard Polyester	Polyester	65	NEMA 4
S	Special Enclosure Type - Configuration Data Sheet Required			
Code	Enclosure Entry			
1	Single Multi-core Cable Gland			
2	Multiple Cable Glands M20x1,5, one per measurement point			
3	Han®-Plug Connection IP65			
4	Customer Specified - Configuration Data Sheet Required			
Code	Insert Tube Material	Maximum Temperature		
		°C	°F	
D	Stainless Steel - DIN 1.4404 (ANSI 316L)	450	842	
P	Inconel®	750	1382	
B	Bundle Only - DIN 1.4404 (ANSI 316L) - No Insertion Tube	450	842	
C	Bundle Only - Inconel - No Insertion Tube	750	1382	
S	Special Tube Material - Customer Specified - Configuration Data Sheet required			
Code	Insert Tube Outer Diameter	Maximum Measuring Points		
00	No Insert Tube (used with Insert Tube Material codes B and C)			
35	3.5 mm (0.14 inch)	25		
45	4.5 mm (0.18 inch)	30		
50	5.0 mm (0.20 inch)	40		
60	6.0 mm (0.24 inch)	60		
80	8.0 mm (0.32 inch)	60		
Code	Insertion Length "L"			
01000	1000 mm (39 inch)			
02000	2000 mm (79 inch)			
03000	3000 mm (118 inch)			
05000	5000 mm (197 inch)			
07000	7000 mm (276 inch)			
10000	10000 mm (394 inch)			
XXXXX	Other lengths {maximum 10000mm (394 inch) with Insert Tube) (maximum 30000 mm (1181 inch) bundle only)			

Note:
Length code is in mm. To convert to mm multiply the length in inches by 25.4.

Models 1080 and 1082

Code Measurement Point Distribution		
A	Equally Distributed Points	
C	Customer Specified—Configuration Data Sheet required	
Code First Measurement Point Location—Distance from base of mounting flange		
00500	500 mm (20 inch)	
01000	1000 mm (39 inch)	
02000	2000 mm (79 inch)	
03000	3000 mm (118 inch)	
04000	4000 mm (158 inch)	
XXXXX	Other Lengths	
Code Mounting Style—Flange Material=DIN 1.4571 (ANSI 316Ti)		Process Connection
F06	Flanged, ANSI	1 inch 150# RF
F12	Flanged, ANSI	1.5 inch 150# RF
F18	Flanged, ANSI	2 inch 150#RF
F24	Flanged, ANSI	1 inch 300# RF
F30	Flanged, ANSI	1.5 inch 300# RF
F36	Flanged, ANSI	2 inch 300# RF
F42	Flanged, ANSI	1 inch 600# RF
F48	Flanged, ANSI	1.5 inch 600# RF
F54	Flanged, ANSI	2 inch 600# RF
F66	Flanged, ANSI	1.5 inch 900# RF
F72	Flanged, ANSI	2 inch 900# RF
D06	Flanged, DIN	DN 25 PN 16
D12	Flanged, DIN	DN 25 PN 40
D18	Flanged, DIN	DN 40 PN16
D24	Flanged, DIN	DN 40 PN40
D28	Flanged, DIN	DN 50 PN 40
CDS	Customer Specified—Configuration Data Sheet Required	
Code Transmitter Options		
Approval Options (consult factory for availability)		
I5	FM Intrinsic Safety and Non-Incendive Approval	
I6	CSA Intrinsic Safety and Non-Incendive Approval	
I7	SAA Intrinsic Safety Approval	
I1	BASEEFA/CENELEC Intrinsic Safety	
Frequency Options		
F5	50 Hz Line Voltage Filter (select this option only if 50 Hz is needed for the Model 848T transmitter. 60 Hz is standard for Model 848T transmitters)	
F6	60 Hz Line Voltage Filter (select this option only if 60 Hz is needed for the Models 644 and 244E transmitters. 50 Hz is standard for Models 644 and 244E transmitters)	
NAMUR Options		
A1	NAMUR Alarm Levels Compliant to NE43	
CN	NAMUR Alarm Levels Compliant to NE43, Set Low	
Code Additional Options		
Special Tagging and Configuration Options		
C1 ⁽¹⁾	Customer specified tagging and transmitter configuration—Configuration Data Sheet Required	
Thermowell Options		
R16	Ring Joint Flange (ASME B16.5 ANSI flanged thermowells only)	
Typical Model Number: 1080C J1 08 A D 1 D 35 01000 A 00500 F36		

(1) Shipped with default transmitter configuration = 0 to 400 °C and default tagging of 1 through the number of measurement points. The first measurement point (closest to the enclosure) is tag "1." If other configuration is required, order option code C1.

Model 1080C Configuration Data Sheet (CDS)

Page One

Copy this form, complete it as required, and fax it to the appropriate fax number listed on the next page

Customer Name: _____

Address: _____

Contact Person: _____

Phone: _____ **Fax:** _____

Date: _____ **Number of Pages:** _____

Rosemount order / Quote number: _____

Model Number _____

Enclosure Type:

- Selected as Standard Option in Model Structure
- Special Requirement: _____

Enclosure Entry:

- Selected as Standard Option in Model Structure
- Special Requirement: _____

Insert Tube Material:

- Selected as Standard Option in Model Structure
- Special Requirement: DIN 1.4401 [ANSI 316]
 Other: _____

Mounting Style:

- Selected as Standard Option in Model Structure
- Special Requirement: Flange Rating:
 - DIN 1.4401 [ANSI 316]
 - DIN 2.4816 [ASTM A494 (Inconel)]
 - Other: _____

Page Two

Measurement Point Distribution:

- Selected as Standard Option in Model Structure
- Special Requirement (fill in table below)

Tagging:

- Default
- Special Requirement (fill in table below)– use with option code C1.

Point	Distance from Mounting Point	Point Tag	Transmitter Tag	Transmitter Range
1				
2				
3				
4				
5				
6				
7				
8				
9				
10				
11				
12				
13				
14				
15				
16				
17				
18				
19				
20				
21				
22				
23				
24				
25				
26				
27				
28				
29				
30				
31				
32				
33				

Up to 60 measurement points that are available with the Model 1080C. For additional points, please attach an additional sheet and include it with the CDS. This sheet should contain the same information as specified above.

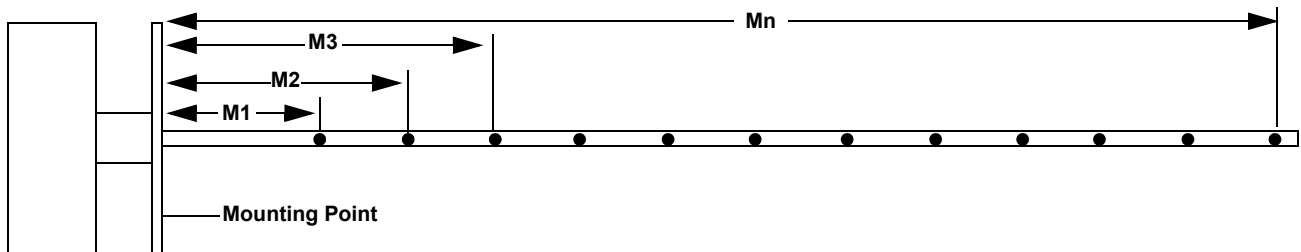

Rosemount Temperature GmbH
 Frankenstrasse 21
 63791 Karlstein
 Germany
 Fax: (49) 6188 992 286
 Phone: (49) 6188 992 0

Rosemount Inc.
 8200 Market Boulevard
 Chanhassen, MN 55317
 USA
 Fax: (1) 952 949 7001
 Phone: (1) 800 999 9307

Fisher-Rosemount
 Singapore Pte Ltd.
 1 Pandan Crescent
 Singapore
 Fax: (65) 777 0947
 Phone: (65) 777 8211

Model 1080F Thermocouple Multipoint Sensor – Contacting Fixture Design

The Model 1080F Multipoint Sensor is versatile, robust, and designed for exceptional reliability with a long life expectancy. The individual measurement elements are ungrounded single thermocouples and the number of measurement points is limited to 20. These sensors are to be used for measurement of temperature profiles where a high local resolution is not required. The Model 1080F can be ordered with or without a thermowell and is available in three different sensor configurations: Individual Guide Tube design, Radial Spring design, and Laminated Spring design.

Individual Guide Tube Design

The individual guide tube design offers the advantage of replaceable individual elements (see Figure 3). Mineral insulated thermocouple elements are inserted into each guide tube and guided to the specified measurement point. When ordered with spring loaded fittings, good thermal contact (fast response time) is achieved but the inside of the thermowell is not sealed from the atmosphere. When ordered with compression fittings, the thermowell is sealed from the atmosphere but the thermal contact isn't as good. The guide tube design, with or without a thermowell, cannot be coiled– which should be considered when shipping.

Radial Spring Design

This design provides good thermal contact between the thermocouple and thermowell. In this design, a radial spring presses the thermocouple against the inner wall of the thermowell. The flattened MI cable has full thermal contact with the thermowell. This design ensures the best possible response time. If ordered without a thermowell, it will be shipped as a coil. The individual thermocouples cannot be replaced.

Laminated Spring Design

This design provides good thermal contact between the thermocouple and the thermowell, facilitating a fast-time response. The laminated spring presses the thermocouple against the inner wall of the thermowell (see Figure 3) and is appropriate if the mounting flange is angled to the thermowell. The advantage of this design is the flexibility of the insert, which is similar to the flexibility of an oil dipstick. This design allows the sensor to follow the contour of the thermowell. If the laminated spring multipoint sensor is ordered without thermowell, it will be shipped as a coil. The individual thermocouples cannot be replaced.

Thermowell

Every Model 1080F requires a thermowell for operation. When the Model 1080F is ordered without thermowell, check the inner diameter of the existing thermowell (see Table). The inner wall of the thermowell must be smooth, especially at the welding joints, to insure that the multipoint sensor will not be damaged during insertion.

Models 1080 and 1082

SPECIFICATIONS

Functional

Number of Measuring Points

2 to 20

Temperature Limits

- Type E and J: -40 to 750 °C (-40 to 1382 °F)
- Type K and N: -40 to 800 °C (-40 to 1472 °F)

Physical

Length Limits

10 m (33 ft) with thermowell— all designs
30 m (99 ft) without thermowell— Radial and Laminated designs only

Physical Dimensions

TABLE 7. Thermowell Diameter for Guide Tube and Laminated Spring Design

Number of Measurement Points	O.D.		I.D.	
	mm	inch	mm	inch
2 to 5	2-inch schedule 80			
	60.33	2.34	49.25	1.94
6 to 8	2 ¹ / ₂ -inch schedule 80			
	73	2.9	59	2.3
9 to 20	3-inch schedule 80			
	88.9	3.5	73.7	2.9

TABLE 8. Thermowell Diameter for Radial Spring Design

Number of Measurement Points	O.D.		I.D.	
	mm	inch	mm	inch
2 to 8	73.0	2.9	59.0	2.3
9 to 20	88.9	3.5	73.7	2.9

Performance

Ambient Temperature Limits

For the enclosures and transmitters is -40 to 80 °C (-40 to 176 °F)

Insulation Resistance

Greater than 1000 MOhm at room temperature, test voltage is 500 VDC.

Accuracy

TABLE 9. Limits of Error Interchangeability for Class I Thermocouples

Type	
E	1.5 °C or 0.004 t ⁽¹⁾ , -40 to 750 °C
J	1.5 °C or 0.004 t ⁽¹⁾ , -40 to 750 °C
K	1.5 °C or 0.004 t ⁽¹⁾ , -40 to 800 °C
N	1.5 °C or 0.004 t ⁽¹⁾ , -40 to 800 °C

(1) Whichever is greater. "t" is in degrees Celsius.

Enclosures

The enclosures are described in "Multipoint Sensor Enclosures" on page 24 and 25.

Individual Sensor Identification Data

By default, sensor 1 is closest to the flange. Remaining points are numbered incrementally. Use the C1 option and the CDS if a different numbering system is desired.

FIGURE 3. Multipoint Sensor Model 1080F Thermocouple Multipoint Sensor–Contacting Fixture Design

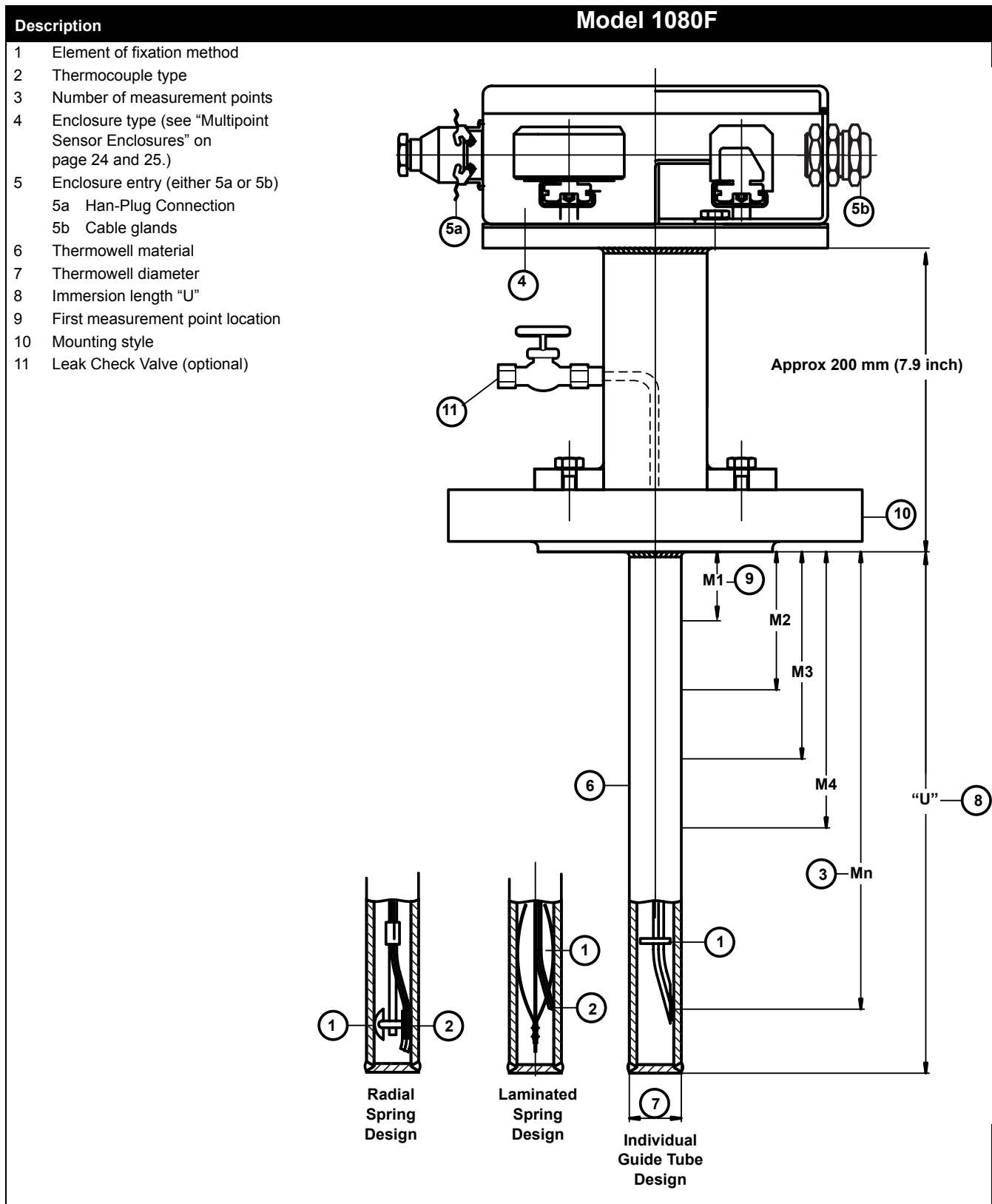

Models 1080 and 1082

ORDERING INFORMATION

Model	Product Description			
1080F	Series 1080F Thermocouple Multipoint Profiling Sensor– Contacting Fixture Design, Tolerance Class 1			
Code	Element Fixation Method			
1	Individual Guide Tubes, Compression Fittings, Replaceable Elements			
2	Individual Guide Tubes, Spring Loaded Fittings, Replaceable Elements			
3	Laminated Spring Design, Compression Fittings, Fixed Elements			
4	Radial Spring Design, Fixed Elements			
Code	Thermocouple Type	Operating Temperature Range		
		°C	°F	
E1	E	-40 to 750	-40 to 1382	
J1	J	-40 to 750	-40 to 1382	
K1	K	-40 to 800	-40 to 1472	
N1	N	-40 to 800	-40 to 1472	
Code	Number of Measurement Points			
03	3			
08	8			
12	12			
16	16			
20	20			
XX	Other Quantities (minimum. 02; maximum. 20)			
Code	Transmitter Type	Maximum Measurement Points		
A	Model 848T Temperature Transmitter–FOUNDATION™ fieldbus	20		
B	Model 644H Temperature Transmitter–HART®	20		
C	Model 244EH Temperature Transmitter–PC-Programmable	20		
N	No Transmitter–Terminal Strip Only	20		
Code	Enclosure Type	Material	IP Rating	NEMA Rating
A	EEx d CENELEC Flameproof Approved (consult factory for availability)	Aluminum	65	NEMA 4
B	EEx e CENELEC Increased Safety Approval (consult factory for availability)	Aluminum	65	NEMA 4
C	EEx i Intrinsically Safety acc. EN 50014 and EN 50020 with manufacturer declaration for Ex i use in Zone 1	Aluminum	65	NEMA 4
D	Standard Aluminum	Aluminum	65	NEMA 4
E	Standard Polyester	Polyester	65	NEMA 4
S	Special Enclosure Type - Configuration Data Sheet Required			
Code	Enclosure Entry			
1	Single Multi-core Cable Gland			
2	Multiple Cable Glands M20x1,5, one per measurement point			
3	Han®-Plug Connection IP65			
4	Customer Specified - Configuration Data Sheet Required			
Code	Thermowell Material	Maximum Temperature		
		°C	°F	
D	Stainless Steel - DIN 1.4404 (ANSI 316L)	450	842	
P	Heat Resistant Steel–DIN 1.7380 (ANSI 182-F22)	800	1472	
S	Special Tube Material - Customer Specified - Configuration Data Sheet Required	Consult factory		
N	No thermowell			
Code	Thermowell Diameter			
A	Standard–see Table and Table			
C	Customer specified–Configuration Data Sheet Required			
Code	Immersion Length “U”			
01000	1000 mm (39 inch)			
02000	2000 mm (79 inch)			
03000	3000 mm (118 inch)			
05000	5000 mm (197 inch)			
07000	7000 mm (276 inch)			
10000	10000 mm (394 inch)			
XXXXX	Other Length {maximum 10000mm (394 inch with thermowell) (maximum 30000 mm (1181 inch) without thermowell– Laminated and Radial Spring designs only)			

Note:
Length code is in mm. To convert to mm multiply the length in inches by 25.4.

Product Data Sheet

00813-0100-4019, Rev BA

November 2002

Models 1080 and 1082

Code Measurement Point Distribution		
A	Equally Distributed Points (last point placed approx 50 mm from the bottom of the thermowell)	
C	Customer Specified—Configuration Data Sheet Required	
Code First Measurement Point Location—Distance from base of mounting flange		
00500	500 mm (20 in)	
01000	1000 mm (39 in)	
02000	2000 mm (79 in)	
03000	3000 mm (118 in)	
04000	4000 mm (158 in)	
XXXXX	Other Lengths	
Code Mounting Style—Flange Material= DIN 1.4404 (ANSI 316L)		Process Connection
F36	Flanged, ANSI	2 inch 300# RF
F74	Flanged, ANSI	2 ¹ / ₂ inch 300# RF
F76	Flanged, ANSI	3 inch 300# RF
F54	Flanged, ANSI	2 inch 600# RF
F78	Flanged, ANSI	2 ¹ / ₂ inch 600# RF
F80	Flanged, ANSI	3 inch 600# RF
F72	Flanged, ANSI	2 inch 900# RF
F82	Flanged, ANSI	2 ¹ / ₂ inch 900# RF
F84	Flanged, ANSI	3 inch 900# RF
D26	Flanged, DIN	DN 50 PN 25/40
CDS	Customer Specified—Configuration Data Sheet required	
Code Transmitter Options		
Approval Options (consult factory for availability)		
I5	FM Intrinsic Safety and Non-Incendive Approval	
I6	CSA Intrinsic Safety and Non-Incendive Approval	
I7	SAA Intrinsic Safety Approval	
I1	BASEEFA/CENELEC Intrinsic Safety	
Frequency Options		
F5	50 Hz Line Voltage Filter (select this option only if 50 Hz is needed for the Model 848T transmitter. 60 Hz is standard for Model 848T transmitters)	
F6	60 Hz Line Voltage Filter (select this option only if 60 Hz is needed for the Models 644 and 244E transmitters. 50 Hz is standard for Models 644 and 244E transmitters)	
NAMUR Options		
A1	NAMUR Alarm Levels Compliant to NE43	
CN	NAMUR Alarm Levels Compliant to NE43, Set Low	
Code Additional Options		
Special Tagging and Configuration Options		
C1 ⁽¹⁾	Customer Specified Tagging and Transmitter Configuration—Configuration Data Sheet required	
Thermowell Options		
Q8	Thermowell Material Certification, DIN EN 10204 3.1.B	
R01	Thermowell Pressure Testing	
R03	Thermowell Dye Penetration Testing	
R07	Full Penetration Weld	
R16	Ring Joint Flange (ASME B16.5 ANSI flanged thermowells only)	
Process Connection Options		
P01	Leak Check Valve	
Typical Model Number: 1080F 2 J1 08 A D 1 D A 01000 A 00500 F36 R01 P01		

(1) Shipped with default transmitter configuration = 0 to 400 °C and default tagging of 1 through the number of measurement points. The first measurement point (closest to the enclosure) is tag "1." If other configuration is required, order option code C1.

Models 1080 and 1082

Model 1080F Configuration Data Sheet (CDS)

Page One

Copy this form, complete it as required, and fax it to the appropriate fax number listed on the next page

Customer Name: _____

Address: _____

Contact Person: _____

Phone: _____ Fax: _____

Date: _____ Number of Pages: _____

Rosemount order / Quote number: _____

Model Number _____

Enclosure Type:

- Selected as Standard Option in Model Structure
- Special Requirement: _____

Enclosure Entry:

- Selected as Standard Option in Model Structure
- Special Requirement: _____

Thermowell Material:

- Selected as Standard Option in Model Structure
- Special Requirement:
 - DIN 1.4401 [ANSI 316]
 - DIN 2.4816 [ASTM A494 (Inconel)]
 - Other: _____

Thermowell Diameter:

- Selected as Standard Option in Model Structure
- Special Requirement:
 - Dimensions in millimeters
 - Dimensions in inches
 - Outer Diameter: _____
 - Inner Diameter: _____

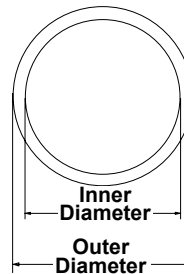

Mounting Style:

- Selected as Standard Option in Model Structure
- Special Requirement:
 - Flange Rating: _____
 - Flange Material:
 - DIN 1.4401 [ANSI 316]
 - DIN 2.4816 [ASTM A494 (Inconel)]
 - Other: _____

Product Data Sheet

00813-0100-4019, Rev BA
November 2002

Models 1080 and 1082

Page Two

Measurement Point Distribution:

- Selected as Standard Option in Model Structure
- Special Requirement (fill in table below)

Tagging:

- Default
- Special Requirement (fill in table below)– use with option code C1.

Point	Distance from Mounting Point	Point Tag	Transmitter Tag	Transmitter Range
1				
2				
3				
4				
5				
6				
7				
8				
9				
10				
11				
12				
13				
14				
15				
16				
17				
18				
19				
20				

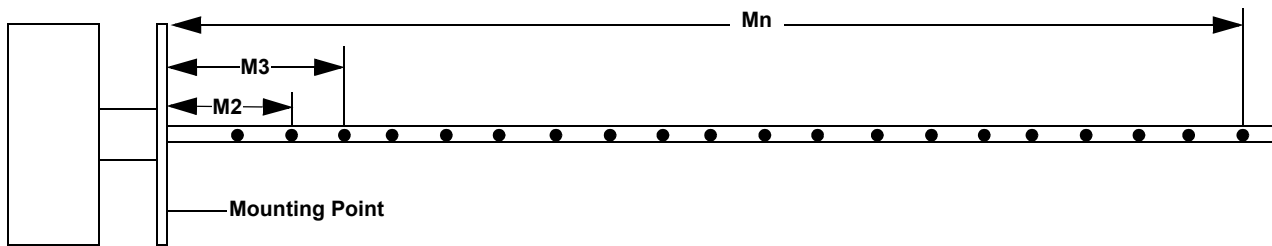

Rosemount Temperature GmbH
Frankenstrasse 21
63791 Karlstein
Germany
Fax: (49) 6188 992 286
Phone: (49) 6188 992 0

Rosemount Inc.
8200 Market Boulevard
Chanhassen, MN 55317
USA
Fax: (1) 952 949 7001
Phone: (1) 800 999 9307

Fisher-Rosemount
Singapore Pte Ltd.
1 Pandan Crescent
Singapore
Fax: (65) 777 0947
Phone: (65) 777 8211

Models 1080 and 1082

Model 1082R RTD Multipoint Sensor— Contacting Fixture Design

The Model 1082R Multipoint Sensor is a robust sensor with a long life expectancy. The individual measurement elements are resistance elements. The standard is a 4-wire RTD, except when the Model 1082R is ordered with Model 848T transmitter (in which case a 3-wire configuration is provided). The number of measurement points is restricted to 12. The Model 1082R is used when a high local resolution is not required. These multipoint sensors can be ordered with or without thermowells.

The Model 1082R is the best solution when data acquisition equipment requires an RTD output signal. However, a thermocouple multipoint sensor (such as the Model 1080F) may be the optimal solution if transmitters are used (higher temperature range, more measurement points, same output). The Model 1082R offers two different element fixation methods the Radial Spring design and the Spacer Design.

Radial Spring Design:

This design provides very good thermal contact between the RTD and the thermowell. A radial spring presses the RTD element against the inner wall of the thermowell ensuring the best possible response time (see Figure 4). If ordered without a thermowell it will be shipped as a coil. The individual RTD elements cannot be replaced.

Spacer Design:

This design (see Figure 4) uses spacer disks to guide the resistance elements into position. The individual RTD elements are not replaceable. For shipping purposes, the spacer design, with or without a thermowell, cannot be coiled.

Thermowell

Every Model 1082R requires a thermowell for operation. When the Model 1082R is ordered without a thermowell, check the inner diameter of the existing thermowell (see Table). The inner wall of the thermowell must be smooth, especially at the welding joints, to insure that the multipoint sensor will not be damaged by insertion.

SPECIFICATIONS

Functional

Number of Measurement Points

2 to 12

Temperature Limits

-40 to 450 °C (-40 to 842 °F)

Physical

Physical Dimensions

TABLE 10. Thermowell Required Diameters for the Radial Spring and Spacer Design

Number of Measurement Points	O.D.		I.D.	
	mm	inch	mm	inch
2 to 8	73	2.9	59	2.3
9 to 12	88.9	3.5	73.7	2.9

Length Limits

10 m (33 ft) with thermowell

30 m (99 ft) without thermowell— Radial Spring design only

Performance

Ambient Temperature Limits

For the enclosures and transmitters is -40 to 80 °C (-40 to 176 °F)

Insulation Resistance:

Greater than 1000 MOhms at room temperature, test voltage is 500 VDC.

Accuracy

TABLE 11. Accuracy in Accordance to DIN EN 60751

Class	
A	$\pm(0.15K+0.0020* t)$
B	$\pm(0.30K+0.0050* t)$
<i>"t" is the temperature in °C.</i>	

Enclosures

The enclosures are described in "Multipoint Sensor Enclosures" on page 24 and 25.

Individual Sensor Identification Data

By default, sensor 1 is closest to the flange. Remaining points are numbered incrementally. Use the C1 option and the CDS if a different numbering system is desired.

FIGURE 4. Multipoint Sensor Model 1082R, Radial Spring and Spacer Design (Pt 100 RTD)

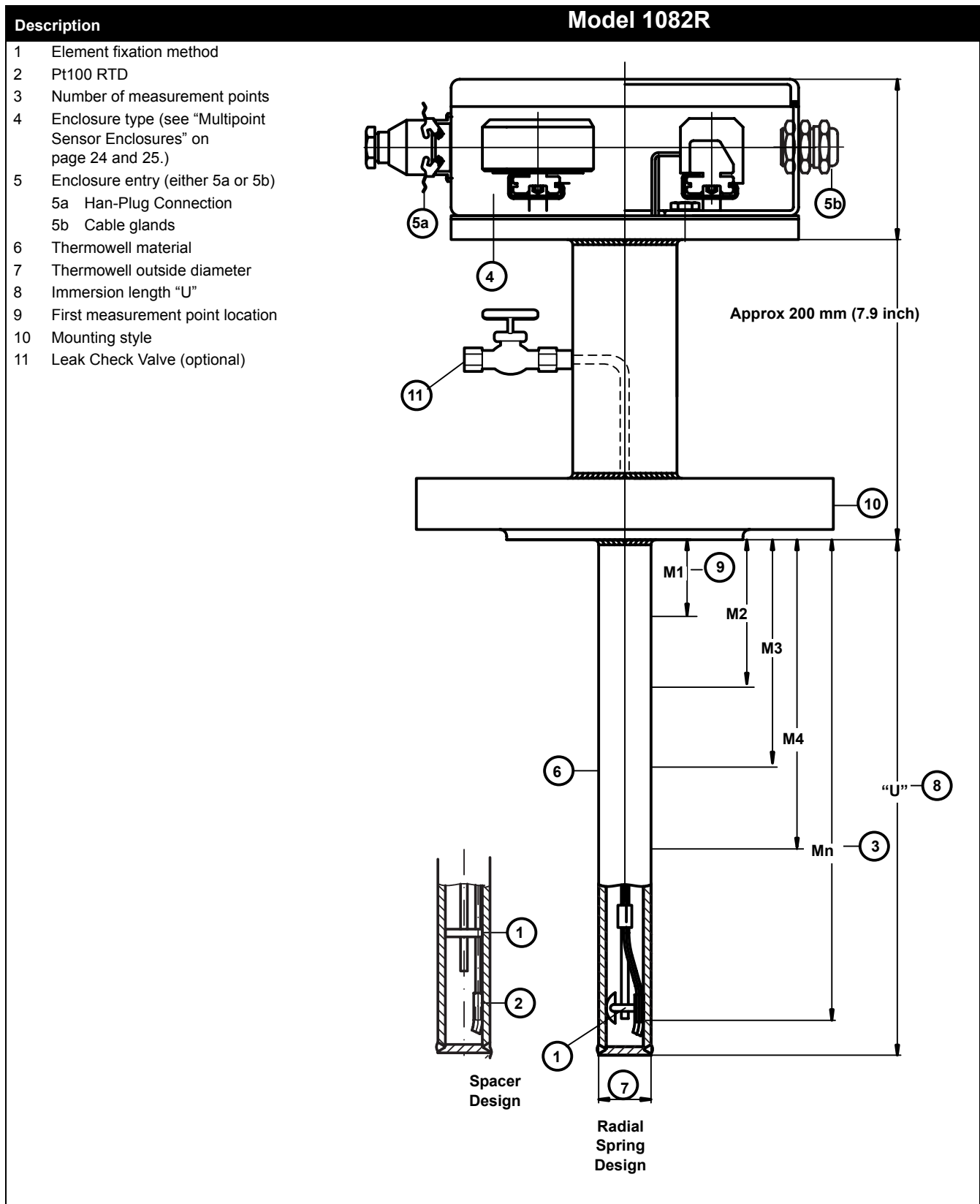

Models 1080 and 1082

ORDERING INFORMATION

Model	Product Description			
1082R	Series 1082R RTD Multipoint Profiling Sensor–Contacting Fixture Design			
Code	Element Fixation Method			
1	Radial Springs Design			
2	Spacer Design			
Code	Sensor Type	Operating Temperature Range		
		°C	°F	
A	Pt100 Class A	–40 to 450	–40 to 842	
B	Pt100, Class B	–40 to 450	–40 to 842	
Code	Number of Measurement Points			
05	5			
08	8			
12	12			
XX	Other Quantities (minimum. 02; maximum. 12)			
Code	Transmitter Type	Maximum Measurement Points		
A	Model 848T Temperature Transmitter–FOUNDATION™ fieldbus	12		
B	Model 644H Temperature Transmitter–HART®	12		
C	Model 244EH Temperature Transmitter–PC-Programmable	12		
N	No transmitter–Terminal strip only	12		
Code	Enclosure Type	Material	IP Rating	NEMA Rating
A	EEx d CENELEC Flameproof Approved (consult factory for availability)	Aluminum	65	NEMA 4
B	EEx e CENELEC Increased Safety Approval (consult factory for availability)	Aluminum	65	NEMA 4
C	EEx i Intrinsically Safety acc. EN 50014 and EN 50020 with manufacturer declaration for Ex i use in Zone 1	Aluminum	65	NEMA 4
D	Standard Aluminum	Aluminum	65	NEMA 4
E	Standard Polyester	Polyester	65	NEMA 4
S	Special Enclosure Type - Configuration Data Sheet Required			
Code	Enclosure Entry			
1	Single Multi-core Cable Gland			
2	Multiple Cable Glands M20x1,5, one per measurement point			
3	Han®-Plug Connection IP65			
4	Customer Specified - CDS required, consult factory			
Code	Thermowell Material	Maximum Temperature		
		°C	°F	
D	Stainless Steel - DIN 1.4404 (ANSI 316L)	450	842	
P	Heat Resistant Steel–DIN 1.7380 (ANSI 182-F22)	750	1382	
S	Special Tube Material - Customer Specified - Configuration Data Sheet Required			
N	No thermowell			
Code	Thermowell Diameter			
A	Standard–see Table			
C	Customer Specified–CDS required			
Code	Immersion Length “U”			
01000	1000 mm (39 inch)			
02000	2000 mm (79 inch)			
03000	3000 mm (118 inch)			
05000	5000 mm (197 inch)			
07000	7000 mm (276 inch)			
10000	10000 mm (394 inch)			
XXXXX	Other Lengths {maximum 10000mm (394 in) with thermowell} (maximum 30000 without thermowell–Radial Spring design only)			

Note:
Length code is in mm. To convert to mm multiply the length in inches by 25.4.

Product Data Sheet

00813-0100-4019, Rev BA

November 2002

Models 1080 and 1082

Code Measurement Point Distribution	
A	Equally Distributed Points (last point placed approx 50 mm from the bottom of the thermowell)
C	Customer Specified—Customer Data Sheet required
Code First Measurement Point Location—Distance from base of mounting flange	
00500	500 mm (20 inch)
01000	1000 mm (39 inch)
02000	2000 mm (79 inch)
03000	3000 mm (118 inch)
04000	4000 mm (158 inch)
XXXXX	Other Lengths
Code Mounting Style—Flange Material= DIN 1.4404 (ANSI 316L) Process Connection	
F36	Flanged, ANSI 2 inch 300# RF
F74	Flanged, ANSI 2 ¹ / ₂ inch 300# RF
F76	Flanged, ANSI 3 inch 300# RF
F54	Flanged, ANSI 2 inch 600# RF
F78	Flanged, ANSI 2 ¹ / ₂ inch 600# RF
F80	Flanged, ANSI 3 inch 600# RF
F72	Flanged, ANSI 2 inch 900# RF
F82	Flanged, ANSI 2 ¹ / ₂ inch 900# RF
F84	Flanged, ANSI 3 inch 900# RF
D26	Flanged, DIN DN 50 PN 25/40
CDS	Customer Specified—Customer Data Sheet Required
Code Transmitter Options	
Approval Options (consult factory for availability)	
I5	FM Intrinsic Safety and Non-Incendive Approval
I6	CSA Intrinsic Safety and Non-Incendive Approval
I7	SAA Intrinsic Safety Approval
I1	BASEEFA/CENELEC Intrinsic Safety
Frequency Options	
F5	50 Hz Line Voltage Filter (select this option only if 50 Hz is needed for the Model 848T transmitter. 60 Hz is standard for Model 848T transmitters)
F6	60 Hz Line Voltage Filter (select this option only if 60 Hz is needed for the Models 644 and 244E transmitters. 50 Hz is standard for Models 644 and 244E transmitters)
NAMUR Options	
A1	NAMUR Alarm Levels Compliant to NE43
CN	NAMUR Alarm Levels Compliant to NE43, Set Low
Code Additional Options	
Special Tagging and Configuration Options	
C1 ⁽¹⁾	Customer Specified Tagging and Transmitter Configuration—Configuration Data Sheet required
Thermowell Options	
Q8	Thermowell Material Certification, DIN EN 10204 3.1.B
R01	Thermowell Pressure Testing
R03	Thermowell Dye Penetration Testing
R07	Full Penetration Weld
R16	Ring Joint Flange (ASME B16.5 ANSI flanged thermowells only)
Process Connection Options	
P01	Leak Check Valve
Typical Model Number: 1082R 1 A 08 A D 1 D A 01000 A 00500 F36 R01	

(1) Shipped with default transmitter configuration = 0 to 400 °C and default tagging of 1 through the number of measurement points. The first measurement point (closest to the enclosure) is tag "1." If other configuration is required, order option code C1.

Models 1080 and 1082

Model 1082R Configuration Data Sheet (CDS)

Page One

Copy this form, complete it as required, and fax it to the appropriate fax number listed on the next page

Customer Name: _____

Address: _____

Contact Person: _____

Phone: _____ Fax: _____

Date: _____ Number of Pages: _____

Rosemount order / Quote number: _____

Model Number _____

Enclosure Type:

- Selected as Standard Option in Model Structure
- Special Requirement: _____

Enclosure Entry:

- Selected as Standard Option in Model Structure
- Special Requirement: _____

Thermowell Material:

- Selected as Standard Option in Model Structure
- Special Requirement:
 - DIN 1.4401 [ANSI 316]
 - DIN 2.4816 [ASTM A494 (Inconel)]
 - Other: _____

Thermowell Diameter:

- Selected as Standard Option in Model Structure
- Special Requirement:
 - Dimensions in millimeters
 - Dimensions in inches
 - Outer Diameter: _____
 - Inner Diameter: _____

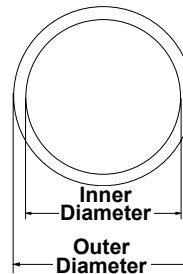

Mounting Style:

- Selected as Standard Option in Model Structure
- Special Requirement:
 - Flange Rating: _____
 - Flange Material:
 - DIN 1.4401 [ANSI 316]
 - DIN 2.4816 [ASTM A494 (Inconel)]
 - Other: _____

Product Data Sheet

00813-0100-4019, Rev BA
November 2002

Models 1080 and 1082

Page Two

Measurement Point Distribution:

- Selected as Standard Option in Model Structure
- Special Requirement (fill in table below)

Tagging:

- Default
- Special Requirement (fill in table below)– use with option code C1.

Point	Distance from Mounting Point	Point Tag	Transmitter Tag	Transmitter Range
1				
2				
3				
4				
5				
6				
7				
8				
9				
10				
11				
12				

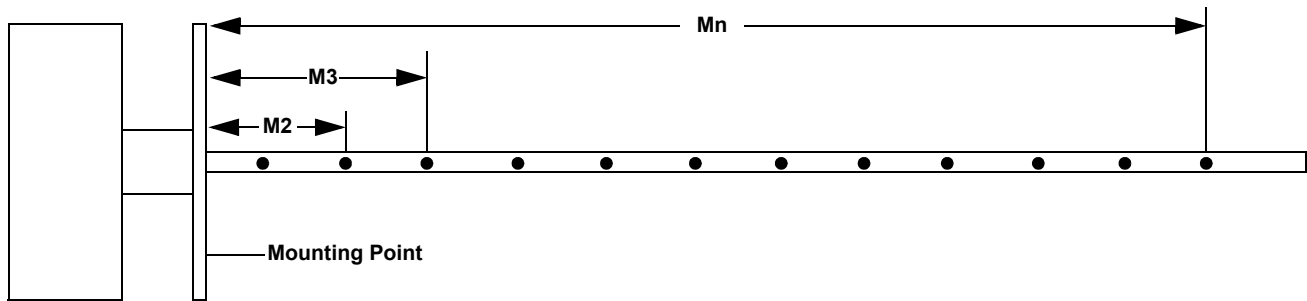

Rosemount Temperature GmbH
Frankenstrasse 21
63791 Karlstein
Germany
Fax: (49) 6188 992 286
Phone: (49) 6188 992 0

Rosemount Inc.
8200 Market Boulevard
Chanhassen, MN 55317
USA
Fax: (1) 952 949 7001
Phone: (1) 800 999 9307

Fisher-Rosemount
Singapore Pte Ltd.
1 Pandan Crescent
Singapore
Fax: (65) 777 0947
Phone: (65) 777 8211

Models 1080 and 1082

Multipoint Sensor Enclosures

Rosemount multipoint sensors are offered in three general enclosure types:

- Aluminum (A)
- Flameproof Aluminum (FPA)
- Polyester (P).

The enclosure size used with a multipoint sensor is determined by three factors, as shown in the tables:

- Multipoint sensors base model
- Number of measurement points
- Type of transmitter

See Table 12 on page 25 to determine the enclosure dimensions.

No Transmitter (enclosure and terminal strip only)

Measurement Points	Number of terminals			Enclosure Size		
	Model 1080C	Model 1080F	Model 1082R	Model 1080C	Model 1080F	Model 1082R
2 – 12	4 – 24	4 – 24	8 – 24	Size 1 (A, P) Size 5 (FPA)	Size 1 (A, P) Size 5 (FPA)	Size 1 (A, P) Size 5 (FPA)
13 – 20	26 – 40	26 – 40	N/A ⁽¹⁾	Size 1 (A, P) Size 5 (FPA)	Size 1 (A, P) Size 5 (FPA)	N/A ⁽¹⁾
21 – 24	42 – 48	N/A ⁽¹⁾	N/A ⁽¹⁾	Size 1 (A, P) Size 5 (FPA)	N/A ⁽¹⁾	N/A ⁽¹⁾
25 – 40	50 – 80	N/A ⁽¹⁾	N/A ⁽¹⁾	Size 2 (A, P) Size 6 (FPA)	N/A ⁽¹⁾	N/A ⁽¹⁾
41 – 60	82 – 120	N/A ⁽¹⁾	N/A ⁽¹⁾	Size 3 (A) Size 4 (F) Size 7 (FPA)	N/A ⁽¹⁾	N/A ⁽¹⁾

(1) Not Applicable

With Model 848T transmitters

Measurement Points	Number of Transmitters	Enclosure Size		
		Model 1080C	Model 1080F	Model 1082R
2 – 8	1	Size 1 (A, P) Size 5 (FPA)	Size 1 (A, P) Size 5 (FPA)	Size 1 (A, P) Size 5 (FPA)
9 – 12	2	Size 3 (A) Size 4 (F) Size 7 (FPA)	Size 3 (A) Size 4 (F) Size 7 (FPA)	Size 3 (A) Size 4 (F) Size 7 (FPA)
14 – 16	2	Size 3 (A) Size 4 (F) Size 7 (FPA)	Size 3 (A) Size 4 (F) Size 7 (FPA)	N/A ⁽¹⁾
17 – 20	3	Size 3 (A) Size 4 (F) Size 7 (FPA)	Size 3 (A) Size 4 (F) Size 7 (FPA)	N/A ⁽¹⁾
21 – 24	3	Size 3 (A) Size 4 (F) Size 7 (FPA)	N/A ⁽¹⁾	N/A ⁽¹⁾
25 – 32	4	Size 3 (A) Size 4 (F) Size 7 (FPA)	N/A ⁽¹⁾	N/A ⁽¹⁾
33 – 40	5	Size 3 (A) Size 4 (F) Size 8 (FPA)	N/A ⁽¹⁾	N/A ⁽¹⁾
41 – 48	6	Size 3 (A) Size 4 (F) Size 8 (FPA)	N/A ⁽¹⁾	N/A ⁽¹⁾

(1) Not Applicable

With Models 644H or 244EH transmitters

Measurement Point	Number of Transmitters	Enclosure Size		
		Model 1080C	Model 1080F	Model 1082R
2 – 8	2 – 8	Size 1 (A, P) Size 5 (FPA)	Size 1 (A, P) Size 5 (FPA)	Size 1 (A, P) Size 5 (FPA)
9 – 10	9 – 10	Size 2 (A, P) Size 6 (FPA)	Size 2 (A, P) Size 6 (FPA)	Size 2 (A, P) Size 6 (FPA)
11 – 12	11 – 12	Size 3 (A) Size 4 (F) Size 7 (FPA)	Size 3 (A) Size 4 (F) Size 7 (FPA)	Size 3 (A) Size 4 (F) Size 7 (FPA)
13 – 20	13 – 20	Size 3 (A) Size 4 (F) Size 8 (FPA)	Size 3 (A) Size 4 (F) Size 8 (FPA)	N/A ⁽¹⁾
21 – 24	21 – 24	Size 3 (A) Size 4 (F) Size 8 (FPA)	N/A ⁽¹⁾	N/A ⁽¹⁾

(1) Not Applicable

TABLE 12. Enclosure dimensions

Size	Length X Width x Depth (mm)	Length X Width x Depth (inch)
1	260 x 160 x 90	10.2 x 6.3 x 3.5
2	360 x 160 x 90	14.2 x 6.3 x 3.5
3	420 x 240 x 210	16.5 x 9.4 x 8.3
4	400 x 405 x 210	15.7 x 15.9 x 8.3
5	298 x 198 x 212	11.7 x 7.8 x 8.3
6	418 x 218 x 212	16.4 x 8.6 x 8.3
7	432 x 332 x 223	17.0 x 13.1 x 8.8
8	632 x 432 x 265	24.9 x 17.0 x 10.4

ENCLOSURES WITH TRANSMITTERS

The drawings below show the maximum number of transmitters that are permitted in the largest enclosure. If a Han plug connection is ordered, only one is required (and is included) with the enclosure.

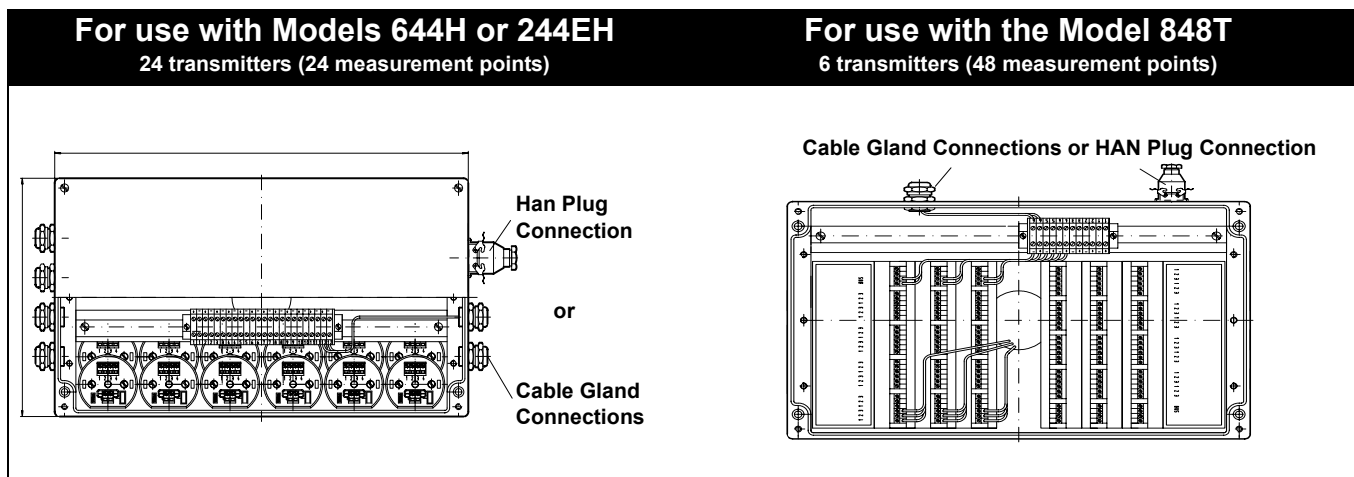

Product Data Sheet

00813-0100-4019, Rev BA

November 2002

Models 1080 and 1082

*Rosemount and the Rosemount logotype are registered trademarks of Rosemount Inc.
PlantWeb is a registered trademark of one of the Emerson Process Management group of companies.
All other marks are the property of their respective owners.*

Emerson Process Management

Rosemount Inc.

8200 Market Boulevard
Chanhassen, MN 55317 USA
T (U.S.) 1-800-999-9307
T (International) (952) 906-8888
F (952) 949-7001

www.rosemount.com

**Rosemount Temperature GmbH**

Frankenstrasse 21
63791 Karlstein
Germany
T 49 (6188) 992 0
F 49 (6188) 992 112

**Emerson Process Management Asia
Pacific Private Limited**

1 Pandan Crescent
Singapore 128461
T (65) 777 8211
F (65) 777 0947
AP.RMT-Specialist@emersonprocess.com



EMERSON™
Process Management