

2102 Wireless Communication Module

Instruction Manual



Part #60-2003-146 of Assembly #60-2003-145
Copyright © 2001, 2002. All rights reserved, Isco, Inc.
Revision C, December, 2002



FOREWORD

This instruction manual is designed to help you gain a thorough understanding of the operation of the equipment. Isco recommends that you read this manual completely before placing the equipment in service.

Although Isco designs reliability into all equipment, there is always the possibility of a malfunction. This manual may help in diagnosing and repairing the malfunction.

If the problem persists, call or email the Isco Customer Service Department for assistance. Contact information is provided below. Simple difficulties can often be diagnosed over the phone. If it is necessary to return the equipment to the factory for service, please follow the shipping instructions provided by the Customer Service Department, including the use of the **Return Authorization Number** specified. **Be sure to include a note describing the malfunction.** This will aid in the prompt repair and return of the equipment.

Isco welcomes suggestions that would improve the information presented in this manual or enhance the operation of the equipment itself.

Contact Information

Phone:	(800) 228-4373 (USA, Canada, Mexico) (402) 464-0231 (Outside North America)
Repair Service:	(800) 775-2965 (Analytical and Process Monitoring Instruments) (800) 228-4373 (Samplers and Flow Meters)
Fax:	(402) 465-3022
Email address:	Info@isco.com
Website:	www.isco.com
Return equipment to:	4700 Superior Street, Lincoln, NE 68504-1398
Other correspondence:	P.O. Box 82531, Lincoln, NE 68501-2531

2102 Wireless Communication Module

Table of Contents

Section 1 Quick Start Guide

1.1	Getting Started	1-1
1.2	Wireless Module	1-2
1.2.1	Identifying Module Components	1-2
1.2.2	Communication Connectors	1-4
1.3	System Connections	1-5
1.3.1	Base Module Connections	1-5
1.3.2	Remote 2100 Site Connections	1-5
1.3.3	Remote 4100/4200/6700 Site Connections	1-5

Section 2 Introduction

2.1	Product Description.	2-1
2.1.1	Wireless Module Overview	2-1
2.2	Applications	2-2
2.3	Controls, Connectors, and Indicators	2-2

Section 3 Preparation and Installation

3.1	Unpacking Instructions	3-1
3.2	Preparing for Installation	3-1
3.2.1	Safety	3-1
3.2.1.1	Site Considerations	3-2
3.3	Installation	3-3
3.3.1	Install the modules	3-4
3.3.2	Testing Installation	3-5

Section 4 Programming

4.1	Section Overview	4-1
4.2	Flowlink Connections	4-1
4.2.1	Communication Resolution (2100 only)	4-3

Section 5 Maintenance

5.1	Maintenance Overview	5-1
5.1.1	Cleaning	5-1
5.2	How to Obtain Service.	5-1

Appendix A Technical Information

A.1	Technical Specifications	A-1
-----	------------------------------------	-----

Appendix B Replacement Parts

B.1	Replacement Parts Diagrams and Listings	B-1
-----	---------------------------------------------------	-----

List of Figures

1-1	Wireless Module Components - Top View	1-2
1-2	Wireless Module Components - Bottom View	1-3
1-3	Upper Connector - Capped	1-4
1-4	Upper Connector - Uncapped	1-4
1-5	Lower Connector - Capped	1-4
1-6	Lower Connector - Uncapped	1-4
1-7	Connections	1-6
2-1	Controls, connectors, and indicators – Model 2102 Wireless Communication Module	2-3
3-1	Assembling a basic system	3-3
4-1	Connections	4-2
A-1	Model 2102 Wireless Communication Module Connector Pins	A-3
B-1	Replacement Parts Diagram – Model 2102 Wireless Communication Module	B-2

List of Tables

1-1	Wireless Module Components - Top View	1-2
1-2	Wireless Module Components - Bottom View	1-3
2-1	Controls, connectors, and indicators – Wireless Module	2-3
4-1	Base Module Connect Cables	4-3
A-1	Specifications – Model 2102 Wireless Communication Module	A-2
A-2	Specifications – Spread Spectrum Radio	A-2
A-3	2191 Battery Module	A-3
A-4	Wireless Module Connector Pins	A-3
B-1	Replacement Parts Listing – Model 2102 Wireless Communication Module	B-3

Flowlink is a registered trademark of Isco, Inc. All other brand and product names are trademarks or registered trademarks of their respective holders.

2102 Wireless Communication Module

Section 1 Quick Start Guide

1.1 Getting Started

This Quick Start Guide provides a basic introduction to the Model 2102 Wireless Communication Module.

In this section we discuss:

- Identifying key components of the Wireless Module
- Module connectors and caps
- System connections

The intent of this section is only to familiarize you with the basics. Detailed information about the installation and operation of this system can be found in the following sections and appendices:

- Section 2, *Introduction*
- Section 3, *Preparation and Installation*
- Section 4, *Programming*
- Section 5, *Maintenance*
- Appendix A, *Technical Information*
- Appendix B, *Replacement Parts*

1.2 Wireless Module

1.2.1 Identifying Module Components

Figures 1-1 and 1-2 identify key components of the Model 2102 Wireless Communication Module.

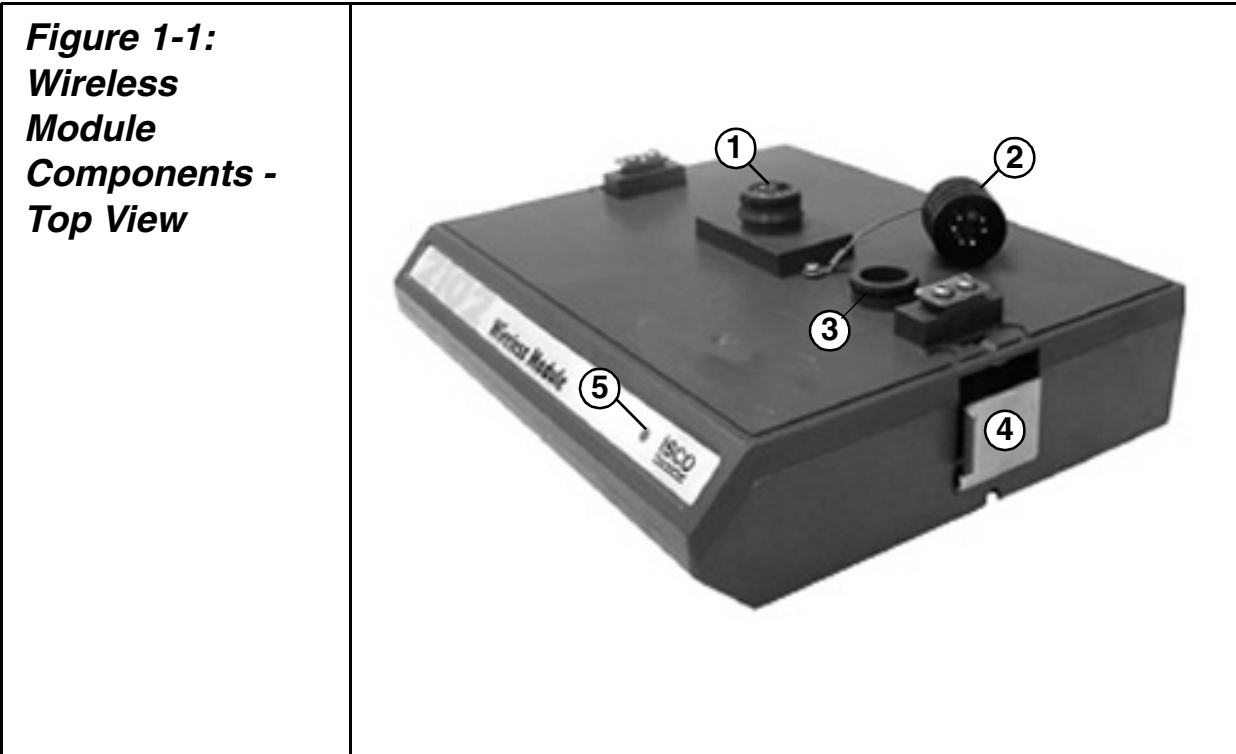

Table 1-1 Wireless Module Components - Top View

Item No. Fig. 1-1	Name
1	Communication Connector
2	Cap
3	Cap Holder
4	Latch Release
5	Communication Indicator

**Figure 1-2:
Wireless
Module
Components -
Bottom View**



Table 1-2 Wireless Module Components - Bottom View

Item No. Fig. 1-2	Description
1	Communication Connector
2	Cap
3	Cap Holder
4	Latch

1.2.2 Communication Connectors

When a communication connector is not in use, the connector must always be capped (Figures 1-3 and 1-5). The cap will seal the connector to prevent corrosion, prevent moisture from entering the unit, and improve communications.

When a communication connector is in use, store the cap on the holder next to the connector (Figures 1-4 and 1-6). The communication connector will be sealed by its mating connector.

 **CAUTION**

Caps **PUSH ON** and **PULL OFF**. Do not rotate the caps to remove them from the connectors.

 **AVIS**

Ne pas tourner les couvercles des connecteurs pour les enlever. Il ne faut que les pousser ou tirer.

 **Note**

For modules to correctly stack and lock together, protective caps between the modules must be stored on the holders.

**Figure 1-3:
Upper Connector -
Capped**

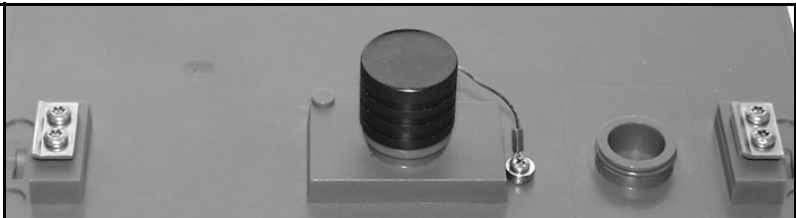

**Figure 1-4:
Upper Connector -
Uncapped**

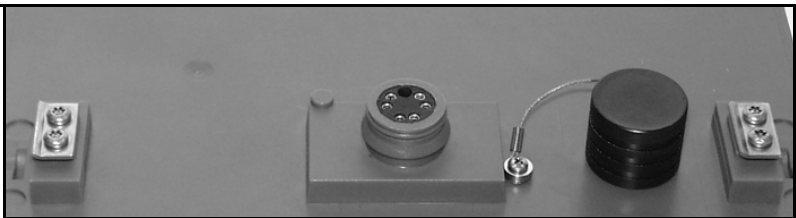

**Figure 1-5:
Lower Connector -
Capped**

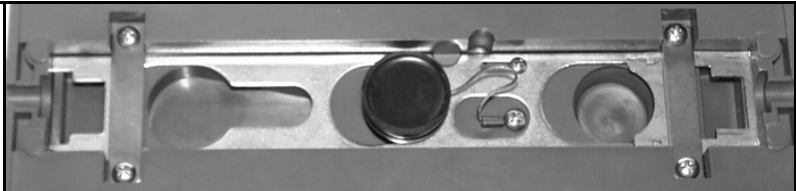

**Figure 1-6:
Lower Connector -
Uncapped**

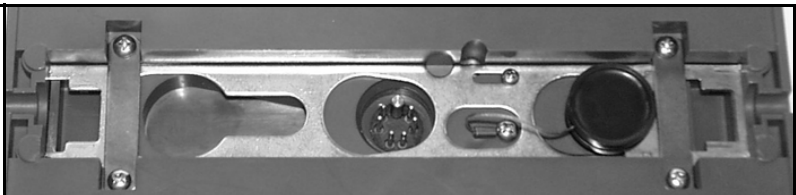

1.3 System Connections

Connections for the 2102 Wireless modules are described as a *base* module and *remote* module. The base wireless module allows a personal computer running *Flowlink for Windows* (v4.11 or later) to communicate with a remote site that is also using a wireless module. Although base and remote modules function differently, they are identical. Designed to be “plug-and-play,” the modules automatically configure themselves according to the device they are connected to.

Typical system connections are shown in Figure 1-7.

1.3.1 Base Module Connections

The base Wireless Module connects to the computer’s COM port with a communication cable (Isco Part Number 60-2004-035 or 60-2004-046).

The base module will also require 12 VDC power. The application will determine which of the three power options you select. For a more permanent installation using a desktop PC, an AC to DC power converter (60-2004-057) would be the most practical choice. Mobile data collection from a vehicle would require the 12 VDC cigarette lighter adapter (60-2004-050). For applications where an external power source is not available, use the Model 2191 Battery Module (60-2004-006).

1.3.2 Remote 2100 Site Connections

To configure the 2100 site with a Wireless Communication Module, simply attach the module to the stack. The Wireless Communication Module will draw power from the Battery Module. If battery life is a concern, a second Battery Module should be added to the stack.

Make sure the 2150 Firmware version is 1.04 or higher. Prior to version 1.04, the unit cycled every two minutes. To change this, the unit must be reconfigured. This is done by holding down the *Shift* key and connecting through the *Quick Connect* dialog.

 **CAUTION**

Reconfiguration will cause all settings and previously collected data to be lost on the unit.

 **AVIS**

La reconfiguration causera tous les paramètres et les données précédemment rassemblées d’être perdues.

1.3.3 Remote 4100/4200/6700 Site Connections

The 2102 may also be used with Isco’s 4100 series Flow Loggers, 4200 series Flow Meters, and 6700 series Samplers.

Software versions for the 4200, 4100, and 6700 series instruments are:

4100 - 1.49 or higher

4200 - 2.21 or higher

6700 - 3.22 or higher

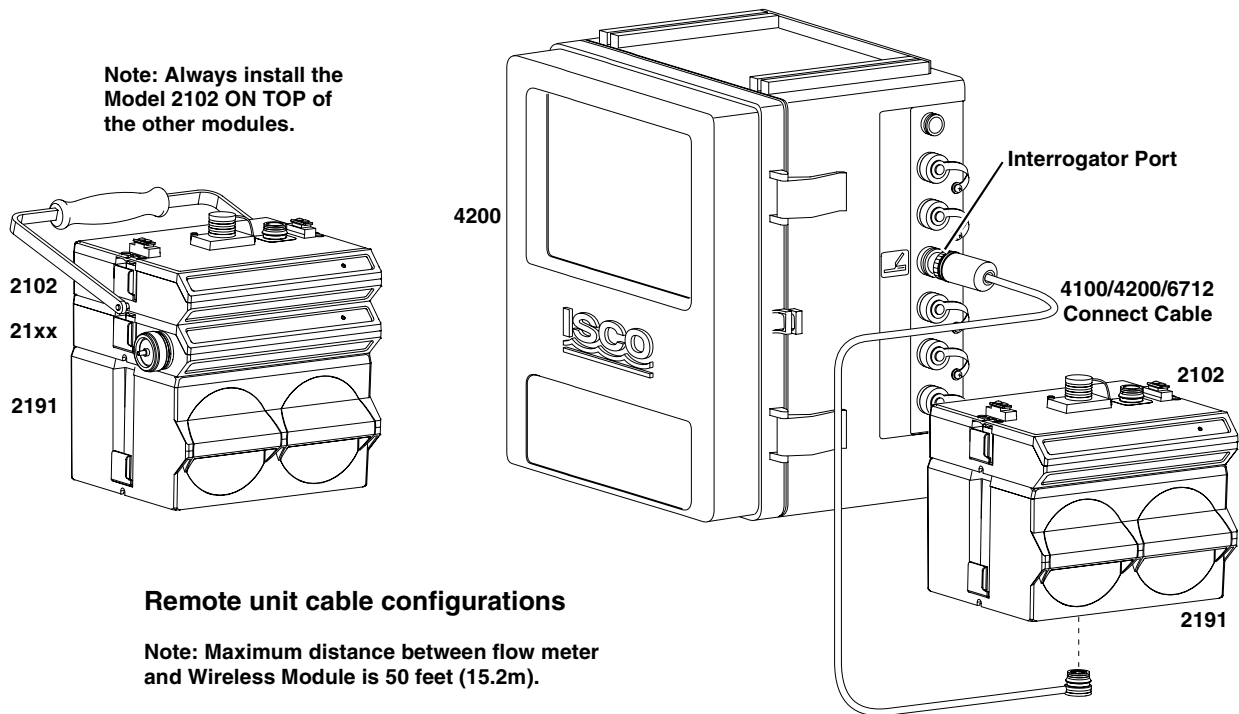
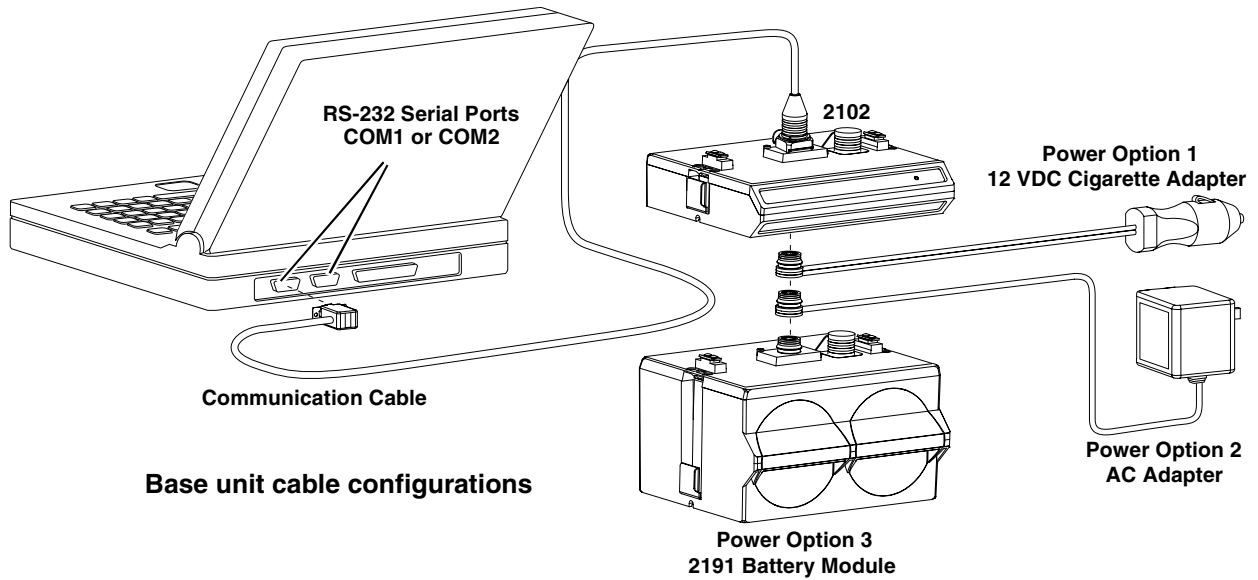
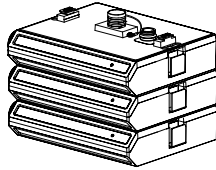

Figure 1-7 Connections

2102 Wireless Communication Module

Section 2 Introduction

2.1 Product Description



A 3-module site

The Model 2102 Wireless Communication Module is part of Isco's Model 2100 Series system. The 2100 Series system measures parameters of open channel flow streams.

The 2100 Series system is designed to be modular so that you can expand the system to meet your data collection needs. By stacking the 2100 Series modules, a single site can measure multiple flow channels, collect redundant data, or add other available measurement capabilities. A site can include remote measurement points, as distant as 3300 feet, by connecting modules with cables. Even with several remote modules configured as a site, you can still retrieve all of the measurement data from a single connection.

The 2100 Series System is supported by Isco's *Flowlink 4 for Windows* software. With this full-featured application, you can quickly set up modules, retrieve measurement data, manage the sites and analyze the data.

The rugged 2100 series components are rated NEMA 4X, 6P (IP68). The permanently sealed enclosures are designed to meet the environmental demands of many sewer flow monitoring applications. All connections between modules, sensors, and communication cables "lock" in place. Each locking mechanism strongly secures the components and ensures a watertight seal.

2.1.1 Wireless Module Overview

The Model 2102 Wireless Communication Modules extend the flexibility of the 2100 system. No longer is flow stream monitoring limited to hard-wired connections or dependent on telephone service. Wireless Modules simplify site selection and data collection.

- No need to open manhole
- "Drive-by"
- safety and comfort
- Isco 2102 Wireless Module stacks with 21xx Area-Velocity Flow Modules
- Powerful Spread Spectrum Digital radio retrieves flow data without manhole entry
- Two-way communication from your vehicle

2102 Wireless Module Features

- No cell phone hassles
- no monthly fees
- no FCC licensing
- no exposed antennas
- Long range
- Long battery life on two 6-volt alkaline batteries

2.2 Applications

Typical applications for the Model 2102 Wireless Communication Module include:

- Sewer Flow
- Inflow and Infiltration (I&I) studies
- Storm Water Runoff Monitoring
- Combined Sewer Overflow (CSO) Monitoring.

2.3 Controls, Connectors, and Indicators

The controls, connectors, and indicators on the Model 2102 Wireless Communication Module are shown in Figures 2-1. Items referenced in the figure are briefly discussed in Table 2-1.

LED Operation for the Remote Unit: When the remote is seeking a connection, the LED will blink. When the connection is made, the LED will light continuously. The remote will also detect when a user direct-connects to the top of the unit. the remote will turn off the radio section and go into standby mode waiting for the connection to be completed. Once the connection is completed (the RS-232 line must be quiet for about 60 seconds), the remote unit will update and normal operation will continue. While in this mode, the LED will blink at a slower two-second interval.

LED Operation for the Base Unit: The LED will light continuously when the radio inside the module is on. Users should not leave the unit plugged into the cigarette lighter after finishing the survey. Standby current in this mode is approximately 40 mA, and will eventually run down a car battery.

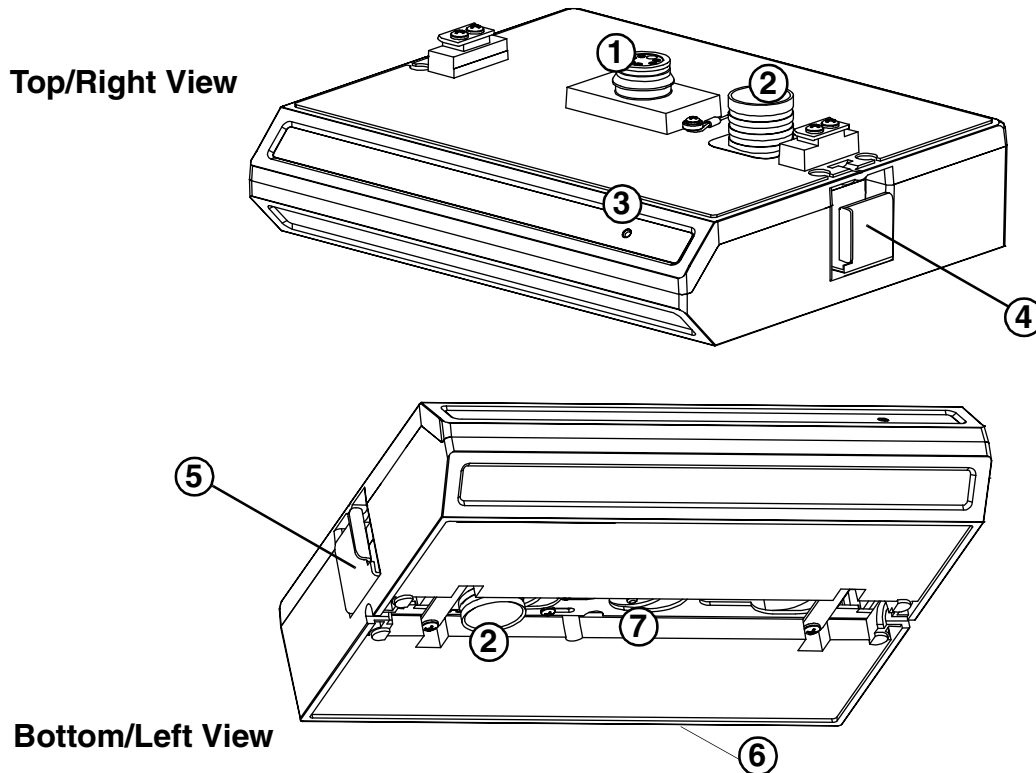

Figure 2-1 Controls, connectors, and indicators – Model 2102 Wireless Communication Module

Table 2-1 Controls, connectors, and indicators – Wireless Module		
Item No. Fig. 2-1	Name	Description
1	Communication Connector	Upper communication port. The connection transfers data and 12 VDC power to other modules. The port may also be used to connect attached modules to a PC running Flowlink 4 software.
2	Connector Caps	Insert into unused communication connectors to terminate the network and protect them from moisture damage. When communication connectors are in use, the caps must be stowed as shown in Figure 2-1 to protect the terminating components inside the caps.
3	Communication Indicator	Illuminates when the module is active.
4	Latch Release	Push in to release the module from a stack.
5	Latch	Push in to lock the module in a stack.
6	Serial Number Label	In back - lists product ID and unit serial numbers.
7	Communication Connector	Lower communication port. The connector transfers data and 12 VDC power to other modules.

2102 Wireless Communication Module

Section 3 Preparation and Installation

3.1 Unpacking Instructions

When the Wireless Module arrives, inspect the outside packing for any damage. Then carefully inspect the contents for damage. If there is damage, contact the delivery company and Isco (or its agent) immediately.

WARNING

If there is any evidence that any items may have been damaged in shipping, do not attempt to install the unit. Please contact Isco (or its agent) for advice.

AVERTISSEMENT

S'il y a d'évidence que les pièces ont été endommagés en transportant, ne tentez pas d'installer l'instrument. Veuillez contacter Isco (ou son agent) pour leurs conseils.

Isco, Inc.
Customer Service Dept.
P.O. Box 82531
Lincoln, NE 68501 USA

Phone: (800) 228-4373
Outside USA & Canada call:
(402) 464-0231

FAX: (402) 465-3022

E-mail: info@isco.com

When you unpack the module, check the items against the packing list. If any parts are missing, contact the delivery company and Isco's Customer Service Department. When you report missing part(s), please indicate them by part number. In addition to the main packing list, there may be other packing lists for various sub-components.

It is recommended that you retain the shipping cartons as they can be used to ship the unit in the event that it is necessary to transport the system.

Please complete the registration card and return it to Isco, Inc.

3.2 Preparing for Installation

3.2.1 Safety

WARNING

The installation and use of this product may subject you to hazardous working conditions that can cause you serious or fatal injuries. Take any necessary precautions before entering a worksite. Install and operate this product in accordance with all applicable safety and health regulations, and local ordinances.

AVERTISSEMENT

L'installation de ces instruments peut vous entraîner à travailler dans des conditions précaires et risquées pouvant entraîner de graves blessures. Veuillez respecter toutes les conditions requises de sécurité avant de pénétrer dans un regard ou sur le site concerné. Installer et manipuler l'instrument selon les règles ou la législation en vigueur concernant la sécurité et la protection des individus.

The Model 2100 Series components are often installed in confined spaces. Some examples of confined spaces include manholes, pipelines, digesters, and storage tanks. These spaces may become hazardous environments that can prove fatal for those unprepared. These spaces are governed by OSHA 1910.146 and require a permit before entering.

3.2.1.1 Site Considerations

Ideal sites are easily accessible for service and data collection, while still providing protection for the Model 2100 Series devices. The 2100 Series devices are rated NEMA 4X, 6P, and constructed of materials that can withstand harsh environments. However, continual exposure to UV light, or periodic submersion should be avoided to extend the life of the components.

Communication between the base and remote modules are rated for distances as great as 1/2 mile (800 meters), line of sight. However, obstructions such as buildings and industrial equipment between the modules may reduce the effective distance.

Typically, the modules are suspended inside a manhole. Suspending the module near the opening will protect it from the elements, minimize the chance of submersion, and allow it to be easily retrieved without entering the manhole. In most instances, this location near the opening will allow for successful wireless communication.

Typical communication distances possible using internal antennas are:

- Line-of-sight: 1/2 mile (0.8 km)
- Inside closed manhole: 100 feet (30m)

3.3 Installation

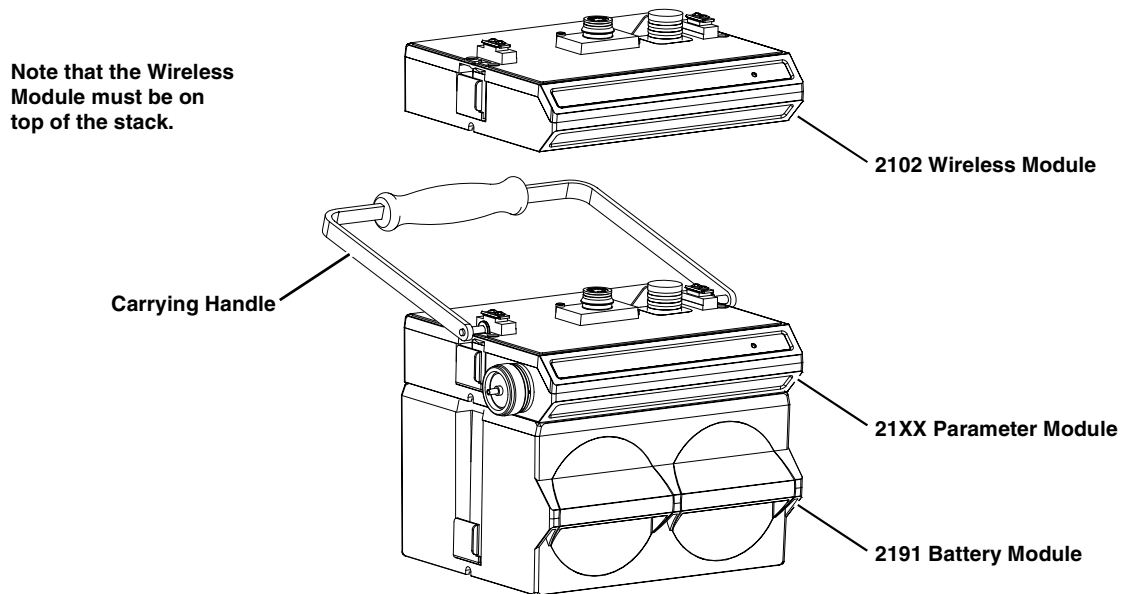

Figure 3-1 Assembling a basic system

Connecting the Modules

To connect the 21xx Parameter and Battery modules, refer to the following instructions and Figure 3-1.

1. On the top of the Battery Module, remove the cap and stow it on the holder. This exposes the communication connector on the Battery Module.
2. Prepare the Battery Module's communication connector:
 - a. Inspect the connector. It should be clean and dry. Damaged O-rings must be replaced. Spare O-rings (Isco P/N 202-1006-69) are supplied in the maintenance kit (60-2099-001).
 - b. Spray the O-ring's sealing surface with a *silicone* lubricant.

Note

Do not use petroleum-based lubricants. Petroleum-based lubricants will cause the O-ring to swell and eventually deteriorate. Aerosol silicone lubricant sprays often use petroleum based propellants. If you are using an aerosol spray, allow a few minutes for the propellant to evaporate before proceeding.

3. Place the carrying handle on the Battery Module. (If you are stacking several modules, it is recommended that you position the handle between the top two modules.)
4. Unlock the Parameter Module's latch by pressing in on the latch release (right side).
5. Underneath the Parameter Module, remove the cap from the lower communication connector and stow it in the holder.

6. Lock the latch. Locking the latch correctly seats and aligns the lower cap in its holder.
7. Position the Parameter Module over the Battery Module. Align the connectors and lower the Parameter Module onto the Battery Module.
8. Unlock the Parameter Module's latch by pressing in on the latch release (right side).
9. Firmly press the modules together and lock the Parameter Module's latch (left side).

The Communications indicator will blink during the start-up routine to indicate the Parameter Module is operating.

Note

Unused communication ports on the top and bottom of the stack must be capped. The connector caps terminate the communication lines and protect the pins.

Note

The 2100 System requires Flowlink 4.1 or later. Earlier versions do not support 2100 System instruments.

10. To install the Wireless Communications Module, repeat the previous steps used to install the Parameter Module on the battery container.

Note

Always install the Wireless Communication Module on top of the other units.

3.3.1 Install the modules

The modules should be secured at the site. This prevents damage caused by accidental falls and from being swept away if the channel is flooded. In manholes, the modules are often secured to a ladder rung, or suspended from a spreader bar. Isco's Customer Service Department or your local representative can assist you with installation options.

Guidelines for the best possibility of successful communications are:

- Locate the remote unit as high up inside the manhole as practically possible. The greater the depth of the remote inside the manhole, the shorter the effective radiating distance. Also bear in mind that inside a manhole, even in best-case situations, the unit will still always be below the surface of the ground and under an iron cover as well.
- Locate the vehicle that contains the base unit as close to the manhole as is safe and reasonable. If possible, for safety reasons, park along the curb, or off-street in a parking lot. Try to park so that there is a clear line of sight

through the windshield of the vehicle to the manhole containing the remote unit. Any obstruction between the manhole and the receiver reduces the chances for successful communications.

- Place the base unit on the dashboard of the vehicle. The radiated energy from the remote unit passes more readily through glass than through the body of a vehicle.
- Suspend the remote unit inside the manhole so the front of the unit faces the center of the manhole; again this optimizes radiation patterns.

As you complete the installation, the following should be checked before leaving the site unattended:

- Make sure the module is on the top rung of the manhole or as close as possible to the surface. Signal transmission will be impaired substantially the deeper the module is mounted in the manhole.
- Make sure the manhole cover is fully replaced and secure.

3.3.2 Testing Installation

 **Note**

The remote wireless module must be connected to a 2100 Series measurement module below it (or other compatible equipment) to function properly. By itself, it cannot measure anything; it is merely a radio frequency transmitter of data generated by the connected measurement module.

When first powered up or after completing a connection, the remote will attempt to connect for 30 seconds. This is a good way to ensure that the unit is operating correctly. If the light does *not* blink for 30 seconds shortly after applying power, the unit is not operating properly.

 **CAUTION**

User should not attempt to operate two base units within the same area. Crosstalk will result and prevent proper operation. This is not the case for the remotes, however. As many remotes as are necessary for the application may be installed.

 **AVIS**

Ne pas essayer de faire fonctionner deux récepteurs (l'unité dans l'auto) dans la même région (moins de 2km). La diaphonie entre les unités résultera. Cependant, on peut utiliser autant de transmetteurs (les unités dans les regards d'égout) que nécessaire sans toute difficulté.

The remote module program is updated when one of the following conditions occurs:

- Power is recycled.
- After a successful connection with a base unit.
- After a direct connection.

2102 Wireless Communication Module

Section 4 Programming

4.1 Section Overview

This section describes how to set up the operation of a Model 21xx Parameter Module using Isco's Flowlink for Windows software.

 **Note**

The 2100 System requires Flowlink 4.1 or later. Earlier versions do not support 2100 System instruments.

Flowlink Help

Detailed Flowlink instructions are beyond the scope of this manual. Flowlink's operating instructions are available in a Windows Help format. You can access the help topics for an active window by clicking on its *Help* button or by pressing F1 on your computer's keyboard. You can also access Help topics from a Contents and Index window (HELP>CONTENTS AND INDEX from the Flowlink menu).

4.2 Flowlink Connections

Make the necessary wiring connections to allow your computer to communicate with the site. Figure 4-1 shows a connection using Isco's *Communication Cable*, P/N 60-2004-035.

There are two ways to connect to a site using a wireless base unit and Flowlink 4.11:

- Quick-Connect method - From the *Quick-Connect* dialog, select Wireless and then press the correct button to select the appropriate type of unit. Note that when using this connection method, you should select the button containing the type of equipment to which the remote is connected. A list of all the sites will appear. You have the option of selecting the site or entering the site name and connecting. You need to know only the site name when connecting to a remote.
- Open Existing Site method - Assuming the site already exists, you may simply open the site and connect or right-click on the site and connect. If a problem occurs, you should confirm that the *Site Info* tab has *Wireless* selected for the type of communication.

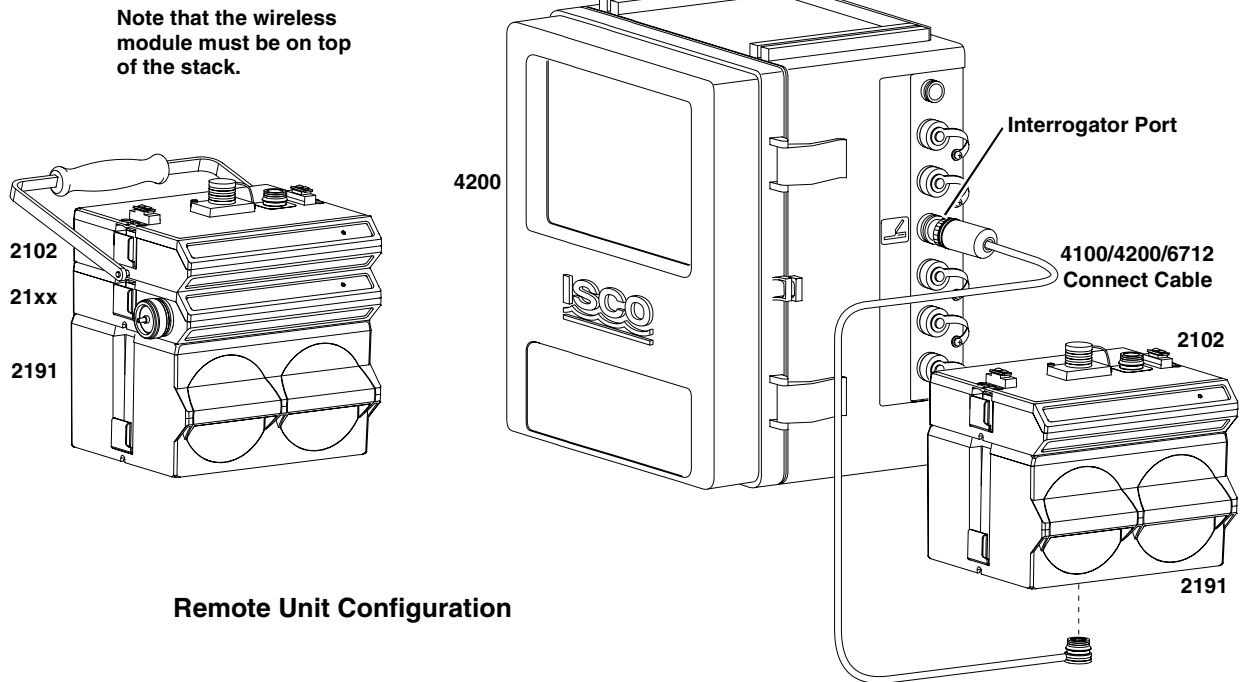
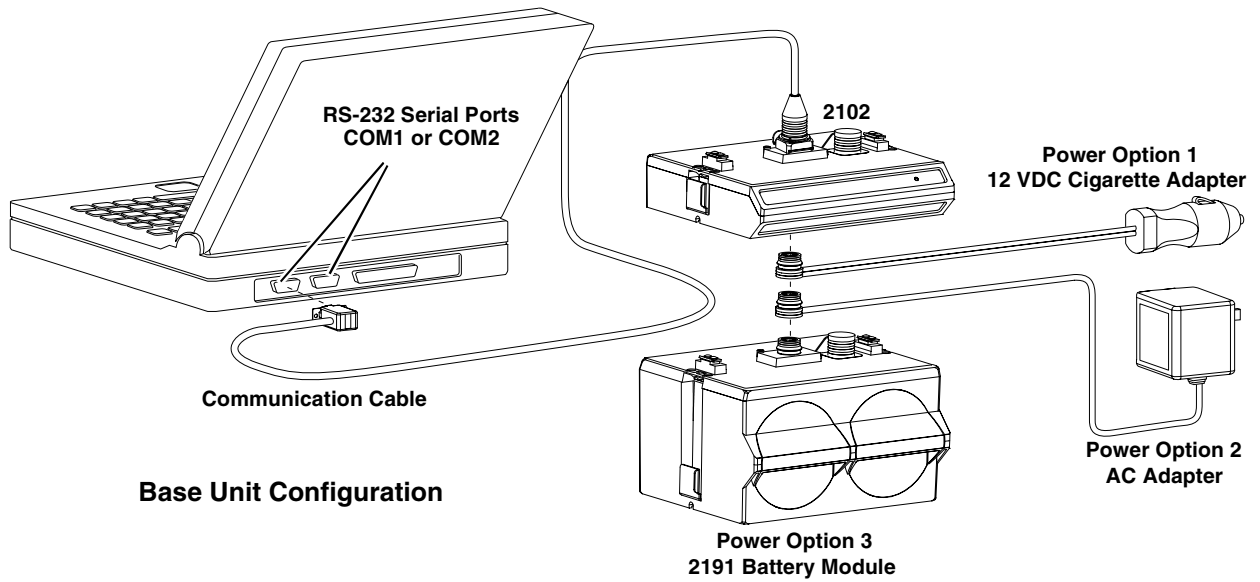

Figure 4-1 Connections

Table 4-1 Base Module Connect Cables

Cable or Power Option (Refer to Fig. 4-1)	Part Number	Description
Communication Cable	60-2004-035 or 60-2004-046	Links the upper communications port of the 2102 (and other 2100 Series Modules) to a PC's 9-pin serial communication port.
Power Option 1	60-2004-050	12 VDC Cigarette Adapter for "drive-by" data collection.
Power Option 2	60-2004-057	AC to 12 VDC Power Converter for more permanent installations. (120 VAC only.)
Power Option 3	60-2004-006	2191 Battery Module with 2 alkaline lantern batteries to power the 2102 Wireless module when 12 VDC or 120 VAC power is not available.

4.2.1 Communication Resolution (2100 only)

During the connection process, Flowlink checks the stability of the site's communications. If communication is found to be unstable, Flowlink presents the *Communication Resolution* window.

There are two common causes of unstable communications. One cause is a Module Name conflict, which may occur when two or more modules at a site use the same module name. The second cause is a Site Name conflict, which occurs when a module added to the site indicates that it belongs to a different site.

The Communications Resolution window lets you choose how the modules should be reconfigured and which Site Name should be retained. To resolve the communications, select the sites and modules that should be reconfigured and click the OK button. Be aware that reconfiguring a module removes the Site Name, Module Name, program settings, and any stored data. The module is then restarted with the stable Site's Name, a default Module Name, and default program settings, and the data storage is ready to accept new data.

2102 Wireless Communication Module

Section 5 Maintenance

5.1 Maintenance Overview

The 2100 Series system is designed to perform reliably in adverse conditions with a minimal amount of routine service requirements.

Maintenance intervals are affected by many variables. The number of modules powered by a Battery Module, the Data Storage Rate, and type of sensor will all affect the battery life. Humidity levels obviously affect the service life of the desiccant, and the amount of debris in the stream can drastically alter the channel conditions.

5.1.1 Cleaning

The Wireless Communication Module case may be cleaned with mild detergent and warm water. Before cleaning the module, make sure that all protective connector caps are in place.

5.2 How to Obtain Service

The internal components of the module are not user-serviceable. The case is completely sealed to protect the internal components. To repair the unit, the case must be broken open and replaced. If you think your module requires repair, contact Isco's Technical Service Department.

Isco, Inc.
Technical Service Dept.
P.O. Box 82531
Lincoln, NE 68501 USA

Phone: (800) 228-4373
(402) 464-0231
FAX: (402) 465-3085

E-mail: service@isco.com

Corresponding with an Isco Technical Service Representative can often resolve the problem without the need to return the item. If the difficulty cannot be resolved you will be issued a Return Authorization Number (RAN) and information on returning it to the factory.

2102 Wireless Communication Module

Appendix A Technical Information

A.1 Technical Specifications

This section lists technical information about the Model 2102 Wireless Communication Module.

- Table A-1 lists the technical specifications of the Model 2102 Wireless Communication Module.
- Table A-2 lists the technical specifications of the Spread Spectrum Radio.
- Table A-3 lists the technical specifications of the Model 2191 Battery Module which must be used with the Model 2102.
- Figure A-1 and Table A-4 list information about the Model 2102 Wireless Communication Module's communication connector.

Table A-1 Specifications – Model 2102 Wireless Communication Module		
Size (H×W×D)	2.9 × 11.3 × 7.5 in.	7.4 × 28.7 × 19.1 cm
Weight	2.0 lbs	0.9 kg
Material	High-impact molded polystyrene	
Enclosure (self-certified)	NEMA 4X, 6P	IP 68
Power	6.6 to 16.6 VDC, 100 mA typical at 12 VDC, 1 mA standby	
Typical Battery Life (one module)	Typical: 50 days (when using two alkaline batteries)	
Carrier Detect Cycle Time	4 minutes	
Average Connection Time	2 minutes	
Operating Temperature	0° to 140°F	-18° to 60°C
Storage Temperature	-40° to 140°F	-40° to 60°C

Table A-2 Specifications – Spread Spectrum Radio	
Frequency	902 to 928 MHz
Transmitter	
Output Power	1 W
Typical Range	
line of sight	0.5 miles (0.8 km)
from inside manhole	100 feet (30 m)
Modulation, GFSK	120 kBs - 170 kBs
Occupied bandwidth	230 kHz
Receiver	
Sensitivity	-108dBm at 10-6 raw BER (bit error rate)
Selectivity	40 dB at fc ±230 kHz 60 dB at fc ±460 kHz
Data Transmission	
Error Detection	32 Bit CRC, resend on error
Data Encryption	Substitution, dynamic key
Link Throughput	115 kBaud
FCC Identifier	KNY-205-108213
DOC (Canada) Identifier	2239 102 336A

Table A-3 2191 Battery Module		
Size (H×W×D)	6.0 × 9.6 × 7.6 in.	15.2 × 24.4 × 19.3 cm
Weight (without batteries)	3.2 lbs	1.4 kg
Material	High-impact molded polystyrene	
Enclosure (self-certified)	NEMA 4X, 6P	IP 68
Batteries	6V alkaline lantern or lead-acid lantern, Quantity 2	
Capacity	Alkaline Lantern Batteries 25 Ampere-hours Lead-Acid Batteries 5 Ampere-hours	
Setup and Data Retrieval	Serial connection to IBM PC or compatible computer with Isco Flowlink for Windows Software Version 4.11 or above.	
Baud Rate	19,200	
Operating Temperature	0° to 140°F	-18° to 60°C
Storage Temperature	-40° to 140°F	-40° to 60°C

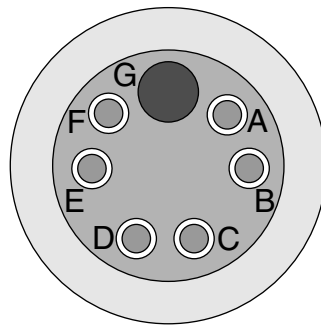

Communications Port
(upper connector shown)

Figure A-1 Model 2102 Wireless Communication Module Connector Pins

Table A-4 Wireless Module Connector Pins		
Pin	Name	Description
A	LONA	Neuron differential transceiver Data A
B	LONB	Neuron differential transceiver Data B
C	VIN+	Positive power supply voltage input (+12 VDC nominal)
D	VIN-	Negative power supply voltage input (0 VDC nominal)
E	RCVUP	PC data receiver RS-232 level input
F	XMTUP	PC data transmit RS-232 level output
G	Key	Aligns connector pins

2102 Wireless Communication Module

Appendix B Replacement Parts

B.1 Replacement Parts Diagrams and Listings

Replacement parts are called out in Figure B-1. Reference the call-out in the adjacent table to determine the part number for the item.

Replacement parts can be purchased by contacting Isco's Customer Service Department.

Isco, Inc.

Customer Service Department
P.O. Box 82531
Lincoln, NE 68501 USA

Phone: (800) 228-4373
(402) 464-0231
FAX: (402) 465-3022

E-mail: info@isco.com

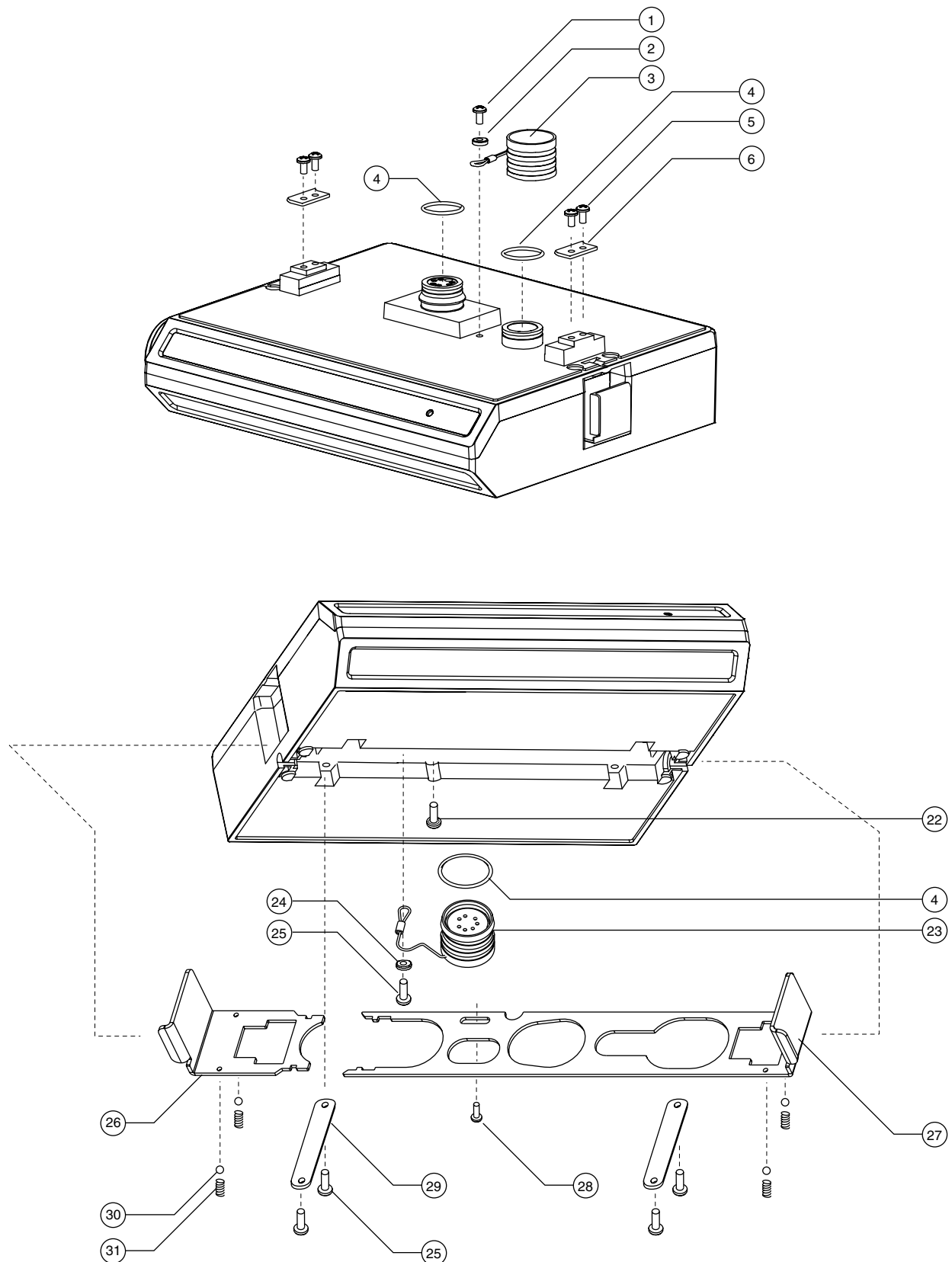

Figure B-1 Replacement Parts Diagram – Model 2102 Wireless Communication Module

**Table B-1 Replacement Parts Listing –
Model 2102 Wireless Communication Module**

Item No. Fig. B-1	Part Number	Description
1	231310106	SCREW, SELF TAPPING, #4
2	602003087	CLAMP SPACER
3	602004012	CAP ASSEMBLY, MALE CONNECTOR
4	202100669	O RING, .650 ID, .079 CROSS SECTION. SILICONE
5	231514920	SCREW, SELF TAPPING, 6-19 X 5/8
6	602003019	NODE CLIP
7		
8		
9		
10		
11		
12		
13		
14		
15		
16		
17		
18		
19		
20		
21		
22	231014322	SCREW, MACHINE, 4-40 X 3/8, PAN, PHILLIPS, STAINLESS STEEL
23	602004013	PLUG ASSY FEM CONN (Includes item 4)
24	602003088	CABLE SPACER
25	231311206	SCREW, SELF TAPPING, #6 X 3/8, PAN, PHILLIPS, STAINLESS STEEL
26	692003079	SMALL LATCH
27	692003078	LARGE LATCH
28	231014306	SCREW, MACHINE, 4-40 X 3/8, PAN, PHILLIPS, STAINLESS STEEL
29	602003022	LATCH HOLD
30	201900102	BALL, .125 DIAMETER, STAINLESS STEEL
31	203011602	COMPRESSION SPRING, .022 DIAMETER WIRE, .31 FREE LENGTH

Isco One Year Limited Factory Service Warranty *

Isco warrants covered products against failure due to faulty parts or workmanship for a period of one year (365 days) from their shipping date, or from the date of installation by an authorized Isco Service Engineer, as may be appropriate.

During the warranty period, repairs, replacements, and labor shall be provided at no charge. Isco's liability is strictly limited to repair and/or replacement, at Isco's sole discretion.

Failure of expendable items (e.g., charts, ribbon, tubing, glassware, seals and filters), or from normal wear, accident, misuse, corrosion, or lack of proper maintenance, is not covered. Isco assumes no liability for any consequential damages.

Isco specifically disclaims any warranty of merchantability or fitness for a particular purpose.

This warranty applies only to products sold under the Isco trademark and is made in lieu of any other warranty, written or expressed.

No items may be returned for warranty service without a return authorization number issued from Isco.

This warranty does not apply to the following products: Process Analyzers, SFX 3560 SFE Extractor, 6100 VOC Sampler.

The warrantor is Isco, Inc. 4700 Superior, Lincoln, NE 68504, U.S.A.

*** This warranty applies to USA customers. Customers in other countries should contact their Isco dealer for warranty service.**

In the event of instrument problems, always contact the Isco Service Department, as problems can often be diagnosed and corrected without requiring an on-site visit. In the U.S.A., contact Isco Service at the numbers listed below. International customers should contact their local Isco agent or Isco International Customer Service.

Return Authorization

A return authorization number must be issued prior to shipping. Following authorization, Isco will pay for surface transportation (excluding packing/crating) both ways for 30 days from the beginning of the warranty period. After 30 days, expense for warranty shipments will be the responsibility of the customer.

Shipping Address: Isco, Inc. - Attention Repair Service
4700 Superior Street
Lincoln NE 68504 USA

Mailing address: Isco, Inc.
PO Box 82531
Lincoln NE 68501 USA

Phone: Repair service: (800)775-2965 (lab instruments)
(800)228-4373 (samplers & flow meters)
Sales & General Information (800)228-4373 (USA & Canada)

Fax: (402) 465-3001

Email: service@isco.com

Isco, Inc.
www.isco.com

